

2016



**[CITY OF KENMORE
2016 ROAD STANDARDS]**

Table of Contents

- Introduction..... 5
- Section 1: Standards 6
 - 1.01 Definitions, Acronyms, and Abbreviations 6
 - 1.02 Companion Documents 7
 - 1.03 Variances..... 8
 - 1.04 Applicability 8
 - 1.05 Authority and Duty of Inspectors 8
 - 1.06 Responsibility to Provide Roadway and Walkway Improvements 9
 - 1.07 Fee in Lieu Option 10
 - 1.08 Cultural Resources 11
 - 1.09 Engineering Plans, Final Corrected Plans, and Final Plat Plans..... 11
 - 1.10 Errors and Omissions 12
 - 1.11 Penalties and Financial Guarantees..... 12
 - 1.12 Changes to this Manual 12
- Section 2: General Requirements..... 13
 - 2.01 Low Impact Development..... 13
 - 2.02 Maintenance 13
 - 2.03 Connectivity 13
 - 2.04 Traffic Impact Analyses 14
 - 2.05 Frontage Improvements 14
 - 2.06 Downtown Frontage Improvements 14
 - 2.07 Dedication of Right-of-Way 17
 - 2.08 Pavement Cut Moratorium..... 17
- Section 3: Street Classification 19
 - 3.01 Public Roads 19
 - 3.02 Private Roads 19
 - 3.03 Alternative Road Designs 20
- Section 4: Construction Control and Inspection..... 21
 - 4.01 Basis for Control of the Work 21
 - 4.02 Inspection..... 21
 - 4.03 Substantial Construction Approval 22
 - 4.04 Final Construction Approval 23
 - 4.05 Penalties for Failure to Notify and Obtain Approval 23

4.06	Control of Materials.....	23
4.07	Construction Control in Developments	24
4.08	Sub-grade.....	24
4.09	Traffic Control During Construction.....	24
4.10	Call Before You Dig.....	26
4.11	Utility Certification.....	26
Section 5: Private Streets, Driveway, and Parking Design.....		27
5.01	General.....	27
5.02	State Highways.....	27
5.03	Private Streets.....	28
5.04	Driveways.....	29
5.05	Parking Lots.....	32
Section 6: Street Design		33
6.01	Reconstruction.....	33
6.02	Applicable Standards	33
6.03	Typical Sections for Existing Arterials and Collector.....	33
6.04	Typical Sections for Residential Access Roads	33
6.05	Typical Sections for Commercial Access Roads	36
6.06	Stopping Site Distance	38
6.07	Entering Site Distance (ESD)	38
6.08	Horizontal Curve Criteria	39
6.09	Vertical Alignment	39
6.10	Street Ends.....	39
6.11	Traffic Calming Devices.....	40
6.12	Alternative Road Design Guidelines.....	42
Section 7: Intersection Design.....		44
7.01	Alignment.....	44
7.02	Spacing.....	44
7.03	Design Vehicles	44
7.04	Curb Radii.....	45
7.05	Drainage.....	45
7.06	Intersection Grades.....	45
7.07	Pedestrian Treatments	45
7.08	Sight Distance Triangle.....	46
7.09	Bicycle Accommodations	46

Section 8: Roadside Features	47
8.01 Sidewalks.....	47
8.02 Curb & Gutters	47
8.03 Construction of Curbs, Gutters, and Sidewalks	47
8.04 Expansion Joints and Sidewalk Finishing	48
8.05 Curb Ramps.....	48
8.06 Concrete Steps and Barrier-Free Access Ramps	49
8.07 Asphalt Shoulders	50
8.08 Bikeways	50
8.09 Fixed Objects.....	50
8.10 Amenity Zone.....	51
8.11 Illumination.....	51
8.12 Landscaping	52
8.13 Mailboxes.....	52
8.14 Cut and Fill Slopes	52
8.15 Guardrail	53
8.16 Vertical Drops	53
Section 9: Surface Treatments	54
9.01 Residential Streets & Sidewalks.....	54
9.02 Requirements for Residential Streets on Poor Subgrade	55
9.03 Arterials and Commercial Access Streets	55
9.04 Street Widening	56
9.05 Overlays	57
9.06 Materials and Lay-Down Procedures:.....	57
9.07 Asphalt Surfacing Repairs:	57
9.08 Pavement Markings, Markers, and Pavement Tapers.....	58
Section 10: Drainage.....	59
10.01 General.....	59
10.02 Road Ditches	59
10.03 Storm Sewers and Culverts.....	59
10.04 Catch Basin Locations and Junctions	60
10.05 Frames, Grates, and Covers	60
10.06 Erosion Control	61
10.07 Underground Structures	61
Section 11: Utilities.....	63

11.01 Franchising Policy and Permit Procedure 63
11.02 Standard Utility Locations within the Right-of-Way 63
11.03 Underground Installations 65
11.04 Inspection & Notification 66
11.05 Final Adjustment (To Finish Grade) 67
11.06 Final Cleanup, Restoration of Surface Drainage and Erosion/Sediment Control 67

Appendix A – Typical Arterial Road Sections

Appendix B – Select Detail Drawings

Introduction

The City of Kenmore strives to create a safe and efficient network of multi-modal transportation throughout the City which serves the needs of its citizens. The City seeks to balance the needs of pedestrians, bicyclists, transit users, freight vehicles, emergency services, and drivers of personal vehicles to create a vibrant and mobile community. The City is conscious of long term maintenance needs and must pair future development with a sustainable maintenance program for public improvements. The City seeks to develop in a manner which provides comfort and aesthetic value to our community. The standards provided in the following document, along with the companion documents listed within these standards, are intended to ensure that future improvements are planned, designed, and constructed in a manner which best meets these City goals and best serves the needs of our citizens.

In addition, these City of Kenmore Road Standards, hereafter known as the Standards, are intended to support the City of Kenmore's goals for providing adequate facilities for development in an efficient manner, complying with storm water management regulations, and preserving environmental and cultural resources while balancing these goals with the general safety and mobility needs of the traveling public.

The City's permitting and licensing activities require the adoption of specific identifiable standards to guide private individuals and entities in the administrative process of procuring the necessary City approval. The City recognizes the need to retain the flexibility to carry out its general duty to provide facilities, streets, roads, and highways for the diverse and changing needs of the traveling public. These Standards are not intended to represent the legal standard by which the City's duty to the traveling public is to be measured, but a standard of design which is flexible to context-sensitive solutions where reasonable and expected care for the safety of the traveling public can be provided.

These Standards cannot provide for all situations. They are intended to assist, but not to substitute for, competent work by design professionals. It is expected that land surveyors, engineers, architects, and contractors will bring to each project the best of skills from their respective area of expertise. These Standards are not intended to limit unreasonably any innovative or creative design efforts or the design of lower impact development alternatives that could result in an equivalent or improved level of safety, , mobility, quality, and maintainability. Environmental constraints may require more intense or rigorous design parameters than would be otherwise required. However, any proposed departure from the Standards will be judged on the likelihood that such variance will produce a compensating or comparable result, in every way safe and adequate for the public.

Section 1: Standards

1.01 Definitions, Acronyms, and Abbreviations

The definitions of term within the Standards shall generally be the same as those listed in the Kenmore Municipal Code except as noted below. Definitions of terms within companion documents shall be as defined within the specific documents being referenced.

- A. **AASHTO** - [American Association of State Highway and Transportation Officials](#)
- B. **ADA** – [Americans with Disabilities Act](#)
- C. **ADA Standards** – For improvements within the right-of-way, the *Proposed Guidelines for Pedestrian Facilities in the Right-of-Way (2011 PROWAG)* published July 26, 2011 by the United States Access Board shall be the standards applied to all new construction or alterations.
- D. **Amenity Zone** – strip of landscaped area between the back of curb and sidewalk which provides a buffer between pedestrians and vehicles and allows room for roadside features to be installed without obstructing pedestrian pathways. In downtown or urban settings, it can be the paved area between the back of curb and the ADA compliant pedestrian route.
- E. **Applicant** – Shall be any person who files an application for a permit from the City of Kenmore and who is either the owner of the land on which that proposed activity would be located, a contract purchaser, or the authorized agent of such a person and shall include any such person who performs work which requires, or required, a permit from the City of Kenmore regardless of whether the permit was actually filed.
- F. **City Manager** – Shall mean the City of Kenmore City Manager or his/her designee(s)
- G. **Contractor** – For all non-City work, shall be interchangeable with ‘applicant’ within these Standards. For City work, the contractor shall be the person or entity contracted directly with the City for construction of improvements, or their designee.
- H. **Developer** – Shall be interchangeable with ‘applicant’ within these Standards.
- I. **Development** – Means any activity upon the land consisting of construction or alteration of structures, earth movement, dredging, dumping, grading, filling, mining, removal of any sand, gravel, or minerals, driving of piles, drilling operations, bulkheading, clearing of vegetation, or other land disturbance. Development includes the storage or use of equipment or materials inconsistent with the existing use. Development also includes approvals issued by the City that bind land to specific patterns of use, including, but not limited to, subdivisions, short subdivisions, zone changes, conditional use permits, and binding site plans. Development does not include the following activities: 1) Interior building improvements; 2) exterior structure maintenance activities (including painting and roofing); 3) Routine landscape maintenance of established, ornamental landscaping, such as lawn mowing, pruning and weeding; or 4) maintenance of the following existing facilities that does not expand the affected area: septic tanks (routine cleaning), wells, individual utility service connections on private property, and individual cemetery plots in established and approved cemeteries.
- J. **DOE** – [Washington State Department of Ecology](#)
- K. **FHWA** – [United States Department of Transportation Federal Highway Administration](#)
- L. **Groundwater** – Any flow which moves laterally beneath the visible surface of an area and which may or may not eventually spring to the surface to create a new source of surface water.
- M. **Inspector** – Unless otherwise noted, shall be the City of Kenmore staff or designee(s) assigned to observe construction and authorized to as noted in Section 4 to approve and/or reject work under these Standards.

- N. **KCSWDM** – [King County Surface Water Design Manual](#) as adopted by KMC 13.35
- O. **KCRS** – [King County Road Design and Construction Standards](#)
- P. **KMC** – [Kenmore Municipal Code](#)
- Q. **MUTCD** - [Manual on Uniform Traffic Control Devices](#)
- R. **NACTO** - [National Association of City Transportation Officials](#)
- S. **RCW** – [Revised Code of Washington](#)
- T. **Sharrows** – A painted marking within a vehicle travel way which indicates that cyclists may use the full lane; typically depicted by a bicycle and two chevrons or arrows pointing in the direction of travel.
- U. **Sidewalk** – Shall mean a formal concrete pedestrian path which is elevated above, or separated from the vehicle travel way, except where otherwise noted.
- V. **Standards** – Shall mean the requirements listed in this document or within the companion documents listed below, or any portion thereof.
- W. **Surface water** – Shall mean water flowing on the surface of any area as a direct result of rainfall on or adjacent to the area; for the sake of these standards, ground water shall not be considered as surface water.
- X. **Undeveloped property or undeveloped parcel** - Shall be any parcel which has not been subdivided to the maximum potential per the minimum lots size permitted in KMC or which is zoned to permit a commercial or multi-family structure which has not been constructed.
- Y. **WAC** – [Washington Administrative Code](#)
- Z. **Walkway** – Shall mean any surface, path, or route which is regularly used by pedestrians; walkways may include sidewalks, paved and un-paved trails, worn foot trails, boardwalks, and shoulders. Existing walkways may include facilities in which the vehicles and pedestrians utilize the same travel way.
- AA. **WDFW** – [Washington State Department of Fish & Wildlife](#)
- BB. **WSDOT** – [Washington State Department of Transportation](#)

1.02 Companion Documents

These standards reference additional industry documents for specific details, materials, and construction guidance and may be utilized when standards of other design criteria are not specifically addressed in this document. The following documents shall be incorporated by reference; future updates to the referenced documents shall be incorporated into these standards upon the effective date of said documents without need for further action. Where updates to referenced information causes the references to become obsolete, or no longer reference the intended information, the City Manager shall be authorized to interpret the intent of the reference. The City Manager shall provide specific interpretation guidance in writing and may determine that additional revisions to the Standards are needed.

- A. Transportation Design Standards
 1. *King County Road Design and Construction Standards* (herein referred to as KCRS), King County Department of Transportation, current edition
 2. *A Policy on Geometric Design of Highways and Streets* (herein reference as AASHTO), AASHTO, current edition
 3. *WSDOT Design Manual*, WSDOT, current edition
 4. *Proposed Guidelines for Pedestrian Facilities in the Right-of-Way* (herein reference as ADA standards or PROWAG), United States Access Board, July 26, 2011

5. *Urban Street Design Guide*, National Association of City Transportation Officials (NACTO), current edition
- B. Surface Water Design Standards
1. *King County Surface Water Design Manual* (here in reference as KCSWDM), King County Department of Natural Resources, current edition; as adopted per KMC 13.35.
 2. *Stormwater Management Manual for Western Washington*, Department of Ecology, current edition
 3. *Highway Runoff Manual*, M31-16.01, WSDOT, current edition
 4. *Low Impact Development Technical Guidance Manual for Puget Sound*, Puget Sound Partnership, current edition
- C. Traffic Control Design Standards:
1. *Manual on Uniform Traffic Control Devices* (herein reference as MUTCD), Federal Highway Administration, current edition
- D. Construction Specifications:
1. *King County Road Design and Construction Standards* (herein referred to as KCRS), King County Department of Transportation, current version
 2. *WSDOT Standard Plans*, WSDOT, current edition
 3. *WSDOT Standard Specifications for Road, Bridge, and Municipal Construction* (herein referred to as 'WSDOT Specs' or 'WSDOT specifications'), WSDOT, current edition
 4. *King County Regulations for Accommodations of Utilities on County Road Rights-of-way*; King County Road Services, current edition

1.03 Variances

Variances from these standards may be granted per the procedures outlined in KMC 12.50.

1.04 Applicability

These standards shall be applicable to all development, new construction, and alterations as outlined in KMC 12.50 and Section 1.06.

1.05 Authority and Duty of Inspectors

The City Manager may designate inspectors to inspect all materials used and all work performed. Such inspection may extend to any or all parts of the work and to the preparation and/or manufacture of the materials to be used. All roadway and drainage infrastructures must be inspected. Paving operation shall not commence until density tests confirm that the compaction is in accordance with the specifications.

- A. The inspector will not be authorized to revise, alter, or relax the provisions of these Standards unless otherwise authorized by the City Manager.
- B. The inspector has the authority to reject defective material and suspend work that is being done improperly.
- C. The inspector may advise the applicant or contractor of any faulty work or materials; however, failure of the inspector to advise the applicant or contractor does not constitute acceptance or approval.

- D. The inspector has the authority to require revisions to approved engineering plans when necessary due to conflicting field conditions.
- E. Unless otherwise addressed in a contract directly between the contractor and the City of Kenmore, the City accepts no responsibility for costs, delays, or loss of profits incurred by the developer, contractor, or any of their representatives, as a result improper work, improper materials, conflicting field conditions, or any direction provided by the City inspector which is consistent with these Standards. It shall be the responsibility of the contractor to verify all field conditions and all information provided, including information provided by the City, prior to beginning construction.

1.06 Responsibility to Provide Roadway and Walkway Improvements

- A. Any development, which will impact the way in which vehicles, transit, pedestrians, or bicyclists move on, through, or between public roadways shall improve those roads in accordance with these Standards. Off-site roadway improvements shall be based on an assessment of the impacts of the proposed land development by the City Manager.
- B. Any development abutting and impacting existing roads, including but not limited to new single family homes, subdivisions, and commercial or multi-family projects, shall improve the frontage of those roads in accordance with these Standards.
 - 1. Only the following types of development projects are exempt from providing frontage improvements:
 - i. Alterations or additions to an existing single family home.
 - ii. Single family projects which reconstruct a previously existing single family home that was demolished within 12 months of the date of filing for the new building permit.
 - iii. Alteration projects on existing commercial structures which do not expand or change the use on site.
 - 2. On flag lots or panhandle lots, which utilize a narrow access stem to develop behind another parcel adjacent to the roadway, the project frontage shall be the segment of roadway equal to the widest portion of the parcel. The full project frontage shall be improved unless otherwise approved by the City Manager. Where the required improvements cannot be installed due to limited or restricted right-of-way along adjacent properties, the applicant shall pay fee in lieu of providing the frontage improvement consistent with Section 1.07.
 - 3. In the case of corner lots, frontage improvements are required on both street frontages.
 - 4. In the case that a project has two non-adjoining frontages, frontage improvements are required on any frontage which will provide access to a new lot or structure or for which a change in traffic patterns, including pedestrian and bicycle traffic, can be reasonably expected.
- C. Any development that contains internal roads, or requires the construction of new roadways to provide access to the proposed lots, structures, or services areas shall construct or improve those roadways in accordance with these Standards.
- D. Subdivisions, short subdivisions, binding site plans or any other land development project which is subject to recording shall not be recorded until there is a recorded continuous public access to the development site, or an access that is covered by a financial guarantee.

- E. All new and reconstructed streets shall provide applicable pedestrian and bicycle improvements that meet the Standards, unless otherwise approved by the City Manager.
- F. Any location where a public roadway is provided on a parcel which abuts a public frontage on one side and undeveloped parcel on the other may be required to provide additional right-of-way dedication to the property line to allow for future road extensions or connections.
- G. Any location where a public roadway is provided on a parcel which abuts an undeveloped parcel, but where vehicle connections cannot be provided or are not required, shall provide and construct a minimum 5 foot walkway within a minimum 10 foot right-of-way through the narrowest portion of property remaining between the edge of the proposed roadway and the adjacent parcel. The public right-of-way shall be clearly distinguished and separated from adjacent private property with fencing, edge treatment, or planting as determined by the City.
- H. Additional walkways may be required where alternative pedestrian paths can provide pedestrian connections between roadways which are:
 - 1. Shorter distance or more favorable terrain than sidewalk along an existing or proposed roadway, or
 - 2. Where pedestrian facilities do not exist along the existing roadway, or
 - 3. Where existing pedestrian routes exist but a formal walkway is not provided, including identified safe routes to school.
- I. Adaptive re-use projects, which involve sites or buildings identified as a Local Landmark per KMC Chapter 2.20, a King County Landmark per the King County Historic Preservation Program, or an Historic Place per the National Register of Historic Places, shall not be required to provide improvements that fully comply with the requirements of Section 1.06; provided that:
 - 1. All projects must still provide safe and adequate access for all users as determined by the City Manager.
 - 2. Projects which include new buildings or expansion of an existing building shall not be considered an 'adaptive re-use project' within the Standards.
- J. Recognizing that the City is a partially built environment which was developed under several different requirements, the City Manager may modify the frontage improvement and/or fee-in-lieu requirements, taking into account constitutional provisions, statutory provisions and court case principles, as well as the development proposal and the conditions of existing site, buildings, and/or adjacent property.

1.07 Fee in Lieu Option

Applicants of developments which require frontage improvements per Section 1.06 may request to pay a voluntary fee in lieu of providing frontage improvements, or any portions of those improvements, to be granted at the discretion of the City Manager. By requesting the voluntary fee option, the applicant agrees that the City Sidewalk Program is an acceptable use of the fee paid. The cost of the fee shall be based on the length of the project frontage and the cost estimates used by the City in the most recent update to the City Sidewalk Program unless otherwise approved by the City Manager. If an alternative cost is approved it must account for the cost of all expected infrastructure required to construct the roadway to these Standards, including storm drainage, grading, and utility relocations, etc. The City reserves the right to deny any request where the physical improvements would be of greater public value than the voluntary fee, as determined by the City Manager.

1.08 Cultural Resources

All impacts to any significant cultural resources shall be avoided to the maximum extent feasible.

For projects sites which are, or contain, an archaeological or cultural resource as defined in [RCW 27.53](#), shall follow the rules and procedures prescribed by the state and shall obtain a permit as required per [RCW 27.53.060](#). All work on the site shall be suspended until evidence of the state permit is provided to the City or until alternative direction is provided in writing to the City from the proper state agency.

1.09 Engineering Plans, Final Corrected Plans, and Final Plat Plans

- A. **Engineering Plans:** Engineering plans for private development proposals shall be prepared and submitted to the City. The engineering plans shall be prepared by a professional engineer licensed in the state of Washington and must be signed and stamped by the responsible professional engineer prior to final acceptance by the City, unless otherwise approved by the City Manager. The engineering plans shall generally comply with Chapter 2 of KCSWDM, including minimum plan size, minimum scale, vertical and horizontal datum, and general content. The City may require supplemental plan elements in addition to those listed in KCSWDM.
- B. **Waiver of Plan Requirements:** Subject to review, the City Manager may waive plan requirements, wholly or in part, based on the following criteria:
 - 1. No more than 2,000 square feet will be cleared and graded; and
 - 2. The work will not intercept a stream, wetland, or sensitive area buffer, or otherwise impact sensitive areas and natural surface drainage as set forth in Kenmore Municipal Code Title 18; and
 - 3. Plans do not include a retention/detention facility; and
 - 4. Kenmore standard drawings, submitted with required permits, are sufficient to describe the improvement to be constructed.
- C. **Record Plans/Final Corrected Plans:**
 - 1. Final corrected plans, or as-built drawings, for archiving shall be required prior to final construction approval for all projects which include improvements within the public right-of-way or improvements that will be maintained or routinely inspected by the City.
 - 2. Final corrected plans shall include as-built information for all improvements within the public right-of-way or improvements that will be maintained by the City and shall be of similar detail as the original design plans.
 - 3. Final corrected plans shall measure and document all elevations, slopes, and dimensions associated with new curb ramps or ADA facilities. Any portion of the ramps or facilities which does not meet ADA requirements shall be removed and replaced with a compliant feature unless justified in Maximum Extent Feasible (MEF) documentation provided by the applicant. The MEF documentation must be stamped and approved by a license engineer and must be approved by the City's ADA Coordinator and City Engineer.
 - 4. Final corrected plans shall be reviewed and approved by the City prior final submittal. Review sets may be submitted electronically or in bond (paper) format.
 - 5. Final submittal of the final corrected plans shall include electronic copies of all plans sheets and the approved TIR as well as select plan sheets in mylar (4 mil. polyester drafting film) format unless otherwise approved by the city Manager.

- D. Maintenance Plans: Engineering plans shall be reviewed to ensure that all road elements proposed for public maintenance will be maintained by the City. Maintenance plans may be required for specialized features.
1. For purposes of public maintenance, a maximum reach of 16 feet by a backhoe type bucket shall be assumed.
 2. For the purposes of public maintenance, a maximum boom reach of 18 feet, measured horizontally from the nearest edge of the access road, for a hydraulic vector truck shall be assumed.

1.10 Errors and Omissions

At the discretion of the City Manager, any errors or omissions in the approved plans or information used as a basis for such approvals may constitute grounds for withdrawal of the approvals and/or stoppage of any or all permitted work. It shall be the responsibility of the applicant, developer, or contractor to show cause for why such work should continue, and make such changes in plans that may be required by the City Manager before the plans are re-approved.

It is the responsibility of the applicant to verify property and right-of-way lines prior to and during construction. Under no circumstances is the City responsible for verification of property lines. Approval of installed improvements does not guarantee that the improvements are installed on the property permitted and does not relieve the applicant of the civil duty or responsibility to correct such errors after becoming aware of the inconstancy.

1.11 Penalties and Financial Guarantees

Failure to comply with these Standards will be cause for denial of permit approval, revocation of prior approvals, withholding and reductions of financial guarantees, withholding final inspection approval, withholding occupancy certificates (temporary and permanent), legal action for forfeiture of financial guarantee, code enforcement, and/or other penalties as provided by law.

- A. PERFORMANCE/RESTORATION FINANCIAL GUARANTEES: Any construction work on City right-of-way (both maintained and unmaintained) which is not performed by the City of Kenmore shall be guaranteed by a restoration financial guarantee unless otherwise approved by the City Manager or waived per KMC Title 21.15.060. The City Manager shall determine the amount and form of the financial guarantee. The minimum restoration and/or performance guarantee shall be \$2,000.00.
- B. MAINTENANCE/DEFECT GUARANTEES: The successful performance of the right-of-way improvements or related drainage facilities shall be guaranteed for a period of at least two years from the date of the Construction Approval, unless otherwise determined by the City Manager or as directed in Kenmore Municipal Code. The City Manager shall determine the amount and form of the maintenance financial guarantee. The minimum maintenance guarantee shall be \$2,000.00.

1.12 Changes to this Manual

The City Manager may incorporate changes to these Standards as they become necessary and may determine the severity of any future proposed revisions. Minor changes to these standards, or revisions to references of updated companion documents, may be incorporated without formal approval.

Section 2: General Requirements

This chapter provides general requirements related to transportation improvements

2.01 Low Impact Development

Low Impact Development (LID) features are encouraged and should be used whenever feasible in street and frontage improvements and as directed in Kenmore Municipal Code (KMC). Where these standards present barriers to the use of LID techniques or best management practices (BMPs) a variance to these Standards shall be considered, provided that the variance does not violate other sections of KMC and is adequately designed for safety, functionality, and maintenance concerns.

2.02 Maintenance

The City will not accept any improvements for maintenance until the improvements have been approved by the City inspector and all performance agreements associate with the improvements have been released by the City. Until the City has accepted the improvements for maintenance, the project applicant shall be responsible for the condition, function, safety, security, and general maintenance of all roadways or improvements.

- A. Only improvements within the right-of-way, or expressly assigned to the City in a recorded document on file with the King County Recorder's Office, will be accepted for City maintenance.
- B. Easements or documents recorded which dedicate maintenance reasonability to the City without written evidence of City approval or acceptance shall be null and shall not be interpreted to assign maintenance responsibility to the City of Kenmore.
- C. Easements not expressly dedicated to the City are to be interpreted as private easements which do not assign a maintenance responsibility to the city of Kenmore.
- D. Easements which grant the City of Kenmore the right of entry for the purposes of inspection shall be interpreted to assign the right of inspection, but not necessarily the responsibility to inspect the improvements within said easement. The City is not responsible for any costs which are associated with the improvements within these types of easements, including cost associated with inadequate maintenance.

2.03 Connectivity

- A. In order to provide connectivity, proposed street layouts shall continue streets to adjacent properties when the adjacent property is an undeveloped parcel or has reasonable chance of re-development in future. This requirement may include additional right-of-way dedication beyond constructed street limits in order to provide for future roadway connections.
- B. To the maximum extent feasible, connections shall be located at the anticipated or logical location which maximizes the development potential of the adjacent parcel.
- C. Pedestrian walkways shall be required to connect roadways where construction of full roadway improvements is not feasible to provide connectivity for vehicles; pedestrian walkways shall be provided to create the shortest route between development and existing walkways, independent of roadway improvements.

2.04 Traffic Impact Analyses

A traffic impact analysis, when required per KMC 17.20.070, shall be completed in accordance with the administrative policies and guidelines determined by City Manager. Currently, the guidelines can be found on City of Kenmore Form #314 *Traffic Impact Analyses Guidelines*.

2.05 Frontage Improvements

Frontage improvements are required per Section 1.06 and may be required in other situations where service level, safety, or operational efficiency of the roads serving a site will be affected.

- A. Frontage improvements shall require bringing half of the frontage road to the full standards for the roadway classification per Section 6 of these Standards. Existing frontage improvements, where existing, shall be upgraded to current safety and design standards.
- B. Standard frontage improvements consist of road widening, right-of-way dedication, new curb & gutter, new sidewalk, new amenity zone and/or landscaping, drainage improvements as needed, street lighting per Section 8.11, relocation of conflicting utilities as needed, and 2-inch half-width grind and overlay along the entire project frontage.
 1. Additional improvements, including transit bus shelters, bus pullouts, utility undergrounding, street lighting, signage, and channelization, may be required to ensure safe movement of traffic, including pedestrians, bicycles, transit, and non-motorized vehicles.
 2. Additional improvements may be required along SR-522 or in the downtown areas as directed in Section 2.06.
- C. Any project which utilizes a zero-foot or modified setback, as permitted by KMC, and places a building too near to the right-of-way line to maintain overhead service without impacting the required walkway or required clear zone shall be required to underground utilities along the entire project frontage.
 1. Additionally, utility undergrounding may be required along SR-522 or in the downtown areas as directed in Section 2.06.

2.06 Downtown Frontage Improvements

Developments along, or which take access from, roadways identified in Figure 2.1 shall provide additional improvements as outlined below.

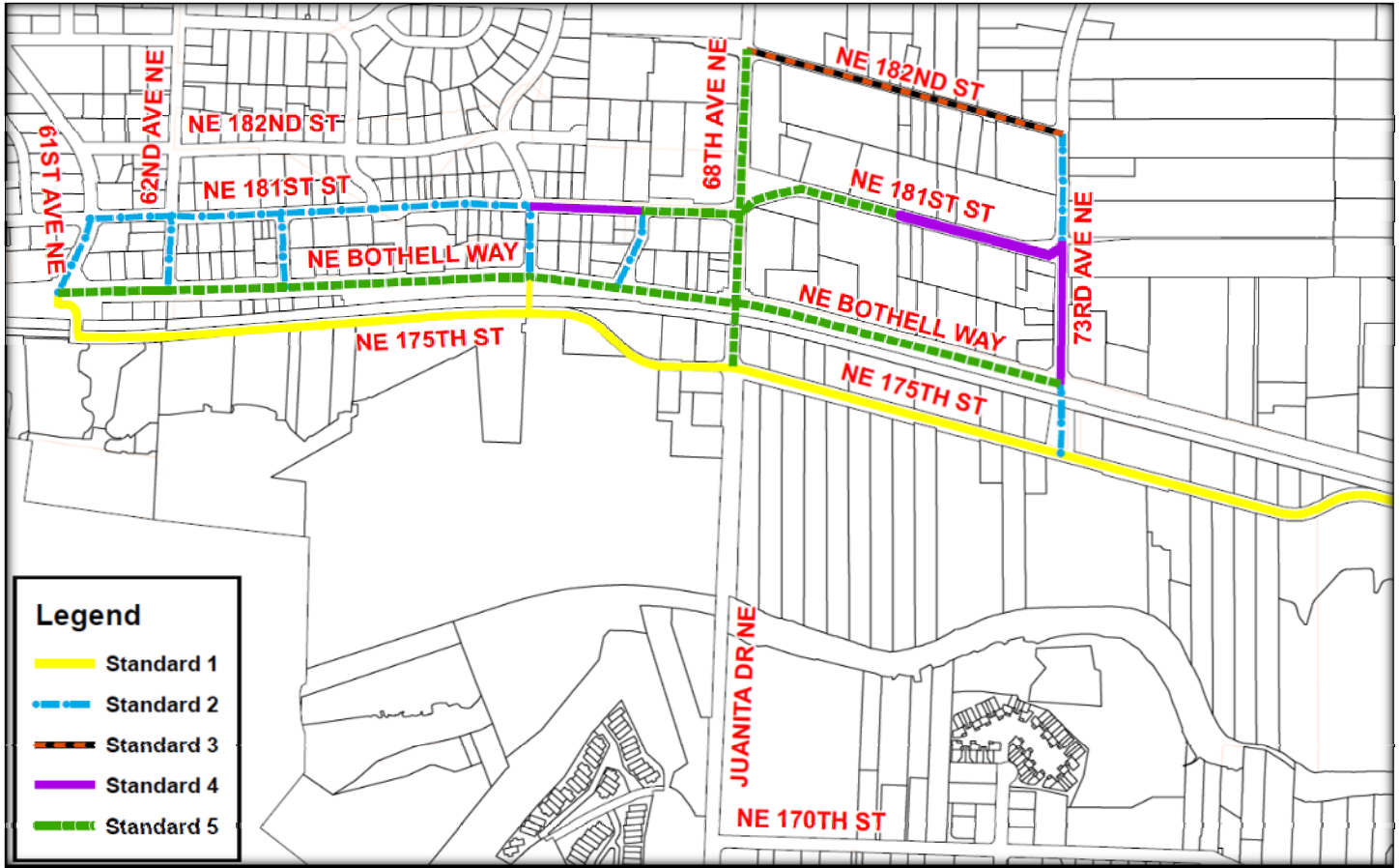

Figure 2.1: Downtown Improvements Map

	Compliance with KMC 18.52.100	Improvement Details to be Determined	Downtown Sidewalk	Downtown Street Trees w/ Irrigation	Electrical Receptacles at Tree Wells	Downtown Street Lighting	Streetlight Banner Brackets	Downtown Pedestrian Lighting	Pedestrian Flower Basket Arms w/ Irrigation	Undergrounding of Existing Utilities in ROW Required	Provide Conduit for Future Undergrounding
	2.06.A	2.06.B	2.06.C	2.06.D	2.06.E	2.06.F	2.06.G	2.06.H	2.06.I	2.06.J	2.06.K
Standard 1	X	X								X	
Standard 2	X		X	X		X		X		X	
Standard 3	X		X	X		X		X			X
Standard 4	X		X	X	X	X	X	X		X	
Standard 5	X		X	X	X	X	X	X	X	X	

Figure 2.2: Downtown Improvements Table

- A. All improvements along roadways identified on Figure 2.1, shall be consistent with direction provided in KMC 18.52.100.
- B. Projects along roadways identified in Figure 2.1 as Standard 1 shall require specialized improvements with exact details for special pavements types, architectural features, and lighting styles to be determined during project design and shall require submitting samples, cut sheets, or shop drawings to the City for approval prior to installation. Projects within this area may be required to match improvement details of other nearby project as developments establish throughout this area.
- C. **Downtown Sidewalk:** Projects along roadways identified in Figure 2.1 as Standard 2, Standard 3, Standard 4, and/or Standard 5 shall provided a minimum 8' wide sidewalk with 2'x2' scoring pattern as follows:
 - 1. Lightly brushed in a transverse direction (perpendicular to roadway) with a soft brush and then a 2 foot by 2 foot grid pattern shall be saw cut into the top of the concrete surface.
 - 2. Sawcuts shall be between 1/4-inch and 3/8-inch deep
 - 3. Sawcut lines shall run perpendicular and parallel to the curb line and shall intersect at 90° angles.
 - 4. Around curves and curb returns, the lines shall be adjusted to be radial so they continue to run perpendicular and parallel to the back of curb
- D. **Downtown Street Trees:** Projects along roadways identified in Figure 2.1 as Standard 2, Standard 3, Standard 4, and/or Standard 5 shall provide street trees, with irrigation, placed at the back of curb at 40 foot centers.
 - 1. 40 foot spacing may be varied from slightly to account for proper site distance, utility placement, or other potential site conflicts, as approved by the City.
 - 2. Landscape areas provided for street tree shall not exceed 4 feet in width and shall always maintain a minimum of 4 feet sidewalk clearance.
 - 3. Irrigation lines shall be provided to each tree well; applicant shall coordinate meter placement & configuration with the water district and City Public Works Department.
 - 4. Tree grates may be optionally provided for these areas upon approval by the City Manager.
- E. **Electrical Receptacles:** Projects along roadways identified in Figure 2.1 as Standard 4 and/or Standard 5 shall include above-ground electrical receptacles, supplied with power, within the pervious area for street trees required per Section 2.06.D above.
 - 1. Future power costs for the electrical receptacle shall be transferred to the City upon City approval.
- F. **Downtown Street Lighting:** Projects along roadways identified in Figure 2.1 as Standard 2, Standard 3, Standard 4, and/or Standard 5 shall provide specialized street lighting as follows (or an approval equal):
 - 1. Head Type(Model Number): Lithonia Aeris Decorative Roadway Led Luminaire (AS1 LED 1 63B30/40K SR 3 240 SPA DF DDBXD)
 - 2. Arm Type (Model Number): Lithonia Aeris Decorative Curved Arm (DCASDDBXDU)
 - 3. Arm length: 2 feet
 - 4. Mounting Height: 35 feet (40 feet along SR-522)
 - 5. Color: Powder coated Bronze Pearlescent (TO25-BR01)
- G. **Streetlight Banner Brackets:** Projects along roadways identified in Figure 2.1 as Standard 4 and/or Standard 5 shall include set of banner brackets on all street lighting required per Section 2.06.F

1. Bracket types and details shall be approved by the City Manager prior to installation and shall be colored to match the light pole.
 2. Brackets shall be installed on side of the pole nearest to the roadway, perpendicular to the direction of travel.
- H. **Downtown Pedestrian Lighting:** Projects along roadways identified in Figure 2.1 as Standard 2, Standard 3, Standard 4, and/or Standard 5 shall provide specialized pedestrian lighting as follows (or an approved equal):
1. Head Type(Model Number): Selux Quadro H2 Led Decorative Pedestrian Luminaire (QH2L-R5-1-4LT500-30-BZ-208)
 2. Mount Height: 14 feet
 3. Color: Powder coated Bronze Pearlescent (TO25-BR01)
- I. **Pedestrian Flower Basket Arms:** Projects along roadways identified in Figure 2.1 as Standard 5 shall provide a set of two mounts, arms, and irrigation for hanging flower baskets on each pedestrian light poles required per Section 2.06.H.
1. The mounts shall be aligned parallel to the roadway on opposite sides of the pole.
 2. Irrigation must be provided to each mount arm.
 3. Mount types and details shall be approved by the City Manager prior to installation and shall be colored to match the light pole.
- J. **Utility Undergrounding:** Projects along roadways identified in Figure 2.1 as Standard 1, Standard 2, Standard 4, and/or Standard 5 shall be required to relocate any existing overhead utility lines along the project frontage into underground conduits in compliance with the utility provider’s specifications and these Standards.
1. Note: All new utility extensions are required to be undergrounded per KMC 13.50.010.
- K. **Underground Conduit Only:** Projects along roadways identified in Figure 2.1 as Standard 3 must provide conduit for future undergrounding, but do not have to remove the existing utility lines or pull wire through the conduit at this time, provided that the building location does not require undergrounding per Section 2.05.C. The project engineer shall review and coordinate the required number and size of conduits needed meet the needs of the existing utility providers.

2.07 Dedication of Right-of-Way

- A. The City may require right-of-way dedication to incorporate necessary transportation and frontage improvements.
- B. Right-of-way dedication width shall be consistent with Section 6 except where additional right-of-way widths have been proposed for projects on the City’s Transportation Improvement Program, the Capital Improvement Program, or the Transportation Element of the Comprehensive Plan.
- C. Right-of-way dedication, when required, shall occur at the time of recording for subdivisions, or prior to issuing the certificate of occupancy on other project types.

2.08 Pavement Cut Moratorium

- A. No pavements cuts will be permitted on any arterial or any street which has been constructed, re-constructed, overlaid, or resurfaced within the past 5-year, except as noted below. All reasonable effort shall be made to utilize trenchless technology for utility installations before an exception is granted.

Unless otherwise approved by the City Manager, pavement cut may only be approved if one of the following is true:

1. The cut is part of an approved project which includes frontage improvements requiring a full-width 2-inch grind and overlay and the cuts are within the limits of the proposed overlay.
2. The cut is allowed through a current franchise agreement as described in the agreement language; where the franchise agreement is silent on restoration requirements, such a cut would require a 2-inch full-width grind and overlay within 20 feet of either side of the trench cut.
3. The cut is for an emergency situation, provided that a 2-inch full-width grind and overlay is provided within 20 feet of either side of the trench cut after the emergency work is completed.
4. A variance from these standards is approved and a 2-inch full-width grind and overlay is provided within 20 feet of either side of the trench cut.

Section 3: Street Classification

3.01 Public Roads

City streets are classified functionally in the *Transportation Element* of the City's Comprehensive Plan. Function is the controlling element for classification and shall govern right-of-way, street width, and street geometrics. Functional classification establishes the hierarchy of streets and highways necessary for a complete transportation system that serves all types of travel needs. Each street has a specified function that produces a comprehensive network for travel and access throughout an area when combined with the rest of the system. The *Transportation Element* of the City's Comprehensive Plan is available on the City's website and a copy is available for viewing at City Hall (18120 68th Ave NE) upon request.

Public roadways shall be constructed to the applicable standards of Section 6 for the corresponding roadway classification.

Public roadways and all constructed improvements or modifications shall remain under the responsibility of the applicant until such time that the City accepts the roadway in writing in accordance with Section 2.02.

3.02 Private Roads

- A. Private streets may be appropriate for some streets which have a limited number of lots.
- B. Private streets on residential projects may be approved only when they are:
 - 1. Classified as an local access street, alley, private access tract, or joint-use driveway and built to the Standards, as set forth in Section 5 and section 6, as appropriate, and
 - 2. Permanently established by right-of-way, tract, or easement providing legal access to each affected lot, dwelling unit, or business of sufficient width to accommodate required improvements. Language on the recorded documents establishing the access permissions shall include provision for future use by adjacent property owners when applicable, and
 - 3. Accessible at all times for emergency and public service vehicle use, and
 - 4. Outside the limit of any planned future public roadways in the present or future street plan per the Kenmore Comprehensive Plan, Transportation Improvement Plan, or Capital Improvement Program, and
 - 5. Not going to result in land locking of parcels, and
 - 6. Designed to serve a maximum potential number of dwelling units that can possibly be served by the road when physical barriers, zoning or other legal constraints are considered; and
 - 7. Maintained by a capable and legally responsible owner or homeowners' association, or other legal entity made up of the benefited property owners, which is clearly assigned on the recorded document granting access permissions; and
 - 8. Clearly described on the face of the plat, short plat, binding site plan, or other document recorded on the title of all affected properties, and
 - 9. Clearly signed at the street location as a private street.
- C. The City will not accept private streets for maintenance as public streets until such streets are brought into conformance with current Kenmore Municipal Code and these Standards and must be approved by the City Manager.
- D. The City will not accept private streets for public roadways if the infrastructure is aged, worn, damage, or failing. Such improvements shall be repaired and reconstructed per these Standards prior to City

acceptance.

- E. The City will not accept private streets within short plats when the roads providing access to the plat are private and already have the potential to serve more than the number of lots specified in Section 5.03 or Section 6.
- D. If a short plat has been proposed on a property to which the only access is over private streets that fail to meet the standards specified in this section, the short plat may be denied, or be required to improve the private street to these Standards based on a determination of its impact by the City Manager.
- E. All commercial access roads and internal roads on commercial or multi-family sites shall be privately maintained unless otherwise approved by the City Manager.

3.03 Alternative Road Designs

The City of Kenmore seeks to promote and encourage the design of roads using the best available sciences and practices. These Standards are intended as general guidelines meant to be applied to a wide range of project types. Where specific projects can be better served by alternative road design elements such as shared spaces, living streets (Woonerf concept), cycle tracks, green alleys, parklets, and curb extensions, the applicant and City staff shall coordinate the alternative design elements and promote the use of such design in a manner that adequately address the safety concern of the City. Some basic guidelines for alternative design types have been provided in Section 6, but do not provide all of the details needed for full construction and implementation of such designs; the project engineer must provide a unique design for such roadway types. Generally, alternative roadway designs shall be privately maintained unless otherwise approved by the City Manager.

Section 4: Construction Control and Inspection

4.01 Basis for Control of the Work

- A. Work performed in the construction or improvement of public or private roads shall be done in accordance with these Standards and approved plans. No work may be started until such plans are approved and a pre-construction meeting is held with the City. Any revision to the approved plans shall be approved by the City before being implemented.
- B. The City Manager is authorized to enforce the Standards as well as other referenced or pertinent specifications or guidelines. He/she will appoint staff as necessary to inspect the work.
- C. Provisions of Section 1-05 of the WSDOT/APWA Standard Specifications shall apply, with the term "Engineer" therein construed to be the City Manager as defined in Section 1.01.

4.02 Inspection

- A. Generally, control and inspection will be done by the City on all privately developed infrastructure, road, and drainage facility construction proposed or in progress by a private developer. The City also performs the maintenance/defect inspections. The City Manager must approve any variances from the Standards during construction.
- B. The applicant is responsible for quality control of construction and the assurance of meeting the standards. City inspectors monitor these activities with enforcement authority when requirements are not met. All work conducted on electrical and communications systems shall be inspected by the Washington State Department of Labor and Industries, unless and until these services are offered by the City.
- C. All materials provided by the applicant shall be subject to inspection and approval by the City Inspector at any time during the progress of work until final acceptance. The applicant's construction schedule shall include sufficient time for materials testing and any required verification by the City Inspector.
- D. The City Inspector has the authority to reject defective material and suspend work that does not meet standards. The City Inspector may advise the applicant or contractor of any faulty work or materials; however, failure of the City Inspector to advise the applicant or contractor does not constitute acceptance or approval. At the City Inspector's order, the applicant/contractor shall immediately remedy, remove, replace, or dispose of unauthorized or defective work or materials and bear all the costs of doing so.
- E. All roadway and drainage infrastructures must be inspected, and approved prior to any final closure of any approved permits for the improvements.
- F. Prior to any critical task being started, the applicant must coordinate with the City inspector. At a minimum, the following critical tasks require advance notification:
 - 1. Preconstruction Conference: Three working days prior notice. Conference must precede the beginning of construction and include the applicant, general contractor, and other applicable participants. Plan approvals, permits, liability insurance coverage, and financial agreements / guarantees must be in hand prior to the conference.
 - 2. Clearing and Temporary Erosion/Sedimentation Control: One working day notice prior to initial site work involving drainage and installation of temporary erosion/sediment control.
 - 3. Curb and Sidewalk Placement: One working day notice to verify proper forming and preparation prior to placing concrete.

4. Structural Inspection for Concrete Walls/Vaults: Per *Special Inspection Sheet* and guidance of City staff
5. Substantial Completion Inspection: 3 working days prior to overall check of road or drainage
6. Final Inspection: 3 working days prior to overall check of entire project
7. Final Maintenance Inspection: 3 working days prior requested inspection date, anytime after expiration of the maintenance and defect period. It is the applicant's responsibility to request final maintenance inspection; the applicant's responsibilities under the terms of the maintenance and defect agreement shall not end until the improvements are formally accepted in writing by the City of Kenmore.

4.03 Substantial Construction Approval

The following section shall be applicable to subdivision projects, site development permits (engineering and grading permits), and commercial building permits.

- A. It shall be the practice of the City of Kenmore to require a minimum level of constructed improvements prior to recording plat documents or issuing a certificate of occupancy and all projects shall obtain substantial completion approval prior to recording final documents.
- B. Substantial completion shall require verification that the following items have been addressed; approvals from agencies other than the City of Kenmore must be provided in writing to the City inspector:
 1. Access provided to all lots within a plat, or to all buildings seeking occupancy.
 - i. For standard asphalt pavements, access is interpreted as a minimum of a first lift of asphalt or asphalt treated base (ATB).
 - ii. For concretes and pervious pavements on internal driveways and private roadways, a compacted gravel surface is acceptable for access; paved surfaces must still be provided within the right-of-way.
 2. Adequate parking provided for the proposed uses of buildings to be occupied.
 3. Required ADA facilities (curb ramps, etc), meeting the latest ADA standards, installed within public right-of-way and for the buildings to be occupied
 4. Frontage improvements installed and substantially complete;
 - i. Sidewalks must be open, unobstructed, safe, and available to public.
 - ii. Striping shall be provided as directed by the City inspector.
 5. Compaction reports for all paved surfaces must be provided to City inspector
 6. Drainage system installed and functional
 7. Water and sewer installed and substantially complete (as determined by the water & sewer district)
 8. Mail delivery system/mailbox installed and approved by the Post Master
 9. Construction equipment, stockpiles, and other materials removed from within the right-of-way and stored on private property with appropriate erosion and sediment control measures in place.
 10. Major safety concerns eliminated (fall hazards, trip hazard, Etc)
 11. All exposed soils temporarily stabilized and all remaining stockpiles covered in compliance with erosion and sediment control standards.

12. All required regulatory signage installed.
13. All required landscaping must be installed or bonded for.
14. All required mitigation plantings must be installed or bonded for.
 - i. On site, mitigation areas or critical areas must be delineated by temporary fencing.
15. All required recreation equipment must be installed or bonded for.
16. Additional performance agreement and financial guarantee filed with the City to ensure timely completion of the project.

4.04 Final Construction Approval

The following section shall be applicable to subdivision projects, site development permits (engineering and grading permits), and commercial building permits.

- A. Prior to closing any permit for site improvements or release of performance bonds associated with a project, the project shall obtain final construction approval.
- B. Final construction approval shall require verification that the following items have been addressed:
 1. All items listed in Section 4.03 except the additional performance agreement (Section 4.03.B.16 above).
 2. All exposed soils or slopes shall be permanently stabilized.
 3. All final punch list items must be addressed as directed by the City inspector.
 4. As-built or final record drawings shall be submitted to and approved by the City.
 5. Verification of the constructed detention volume from licensed engineer or surveyor.
 6. All required roadway monuments shall be installed and a licensed surveyor shall provide written statement that the monuments have been correctly installed.
 7. Critical areas shall be permanently delineated and required signage shall be installed.
 8. Required documentation and fees for maintenance and defect period must be submitted to the City.

4.05 Penalties for Failure to Notify and Obtain Approval

Notification by the applicant or the applicant's contractor, at the necessary time frames noted above, is essential for the City to verify, through inspection, that the work meets the standards. Failure to notify and obtain approval will result in the City requiring sampling and testing with certification by a City approved laboratory. Costs of such testing and certification shall be borne by the applicant. If the test results conclude that the unauthorized work doesn't meet the Standards, the applicant will be required to remove the unauthorized material and replace it with materials that meet the Standards at his/her own expense. At the time that such action is directed by the City Manager, further work on the development may be limited or prohibited until all directed tests have been completed, approved, and all corrections identified by the City have been made to the satisfaction of the City Manager. If necessary, the City may take further action as set forth in KMC 1.20.

4.06 Control of Materials

- A. Source of Supply and Quality of Materials: The contractor shall notify the City of proposed sources of supply for all materials to be furnished. The City shall approve the source of supply of each of the

materials before the delivery is started. Representative preliminary samples or test data of the character and quality prescribed may be required to be submitted by the contractor or producer for examination.

Only materials conforming to the requirements of the WSDOT/APWA Standard Specifications shall be used in the work, unless otherwise approved by the City Manager. Any material proposed to be used may be inspected or tested at any time during their preparation and use. If after testing it is found that sources of supply that have been approved do not furnish a uniform product, or if the product from any approved source proved unacceptable at any time, the contractor shall furnish approved materials from other approved sources. Any approved material that becomes unfit shall not be used.

- B. Samples and Tests: The applicant is required to retain the services of a certified testing laboratory to conduct necessary field and/or lab tests of materials or methods. All testing shall be in accordance with WSDOT and/or AASHTO standards. Materials shall not be used until approved.

The City shall be furnished certified copies of the complete test reports directly from the testing laboratory.

4.07 Construction Control in Developments

The provisions of Section 2-03 of the WSDOT/APWA Standard Specifications apply in all respects to development construction unless otherwise approved by the City Manager.

4.08 Sub-grade

In preparing the roadbed for surfacing before any paving, the requirements outlined in Sections 2-06.3(1) and 2-06.3(2) of the WSDOT/APWA Specifications shall be met. After the subgrade preparation has been completed, it shall be thoroughly checked by the applicant/contractor using a level, string line, crown board, or other means to determine that the subgrade conforms to the approved roadway section and the Standards prior to placing any surfacing material.

4.09 Traffic Control During Construction

- A. Interim Traffic Control: The applicant/contractor shall be responsible for interim traffic control during construction on or along traveled City streets. When road or drainage work is to be performed on City streets that are open to traffic, the applicant/contractor will be required to submit a traffic control plan for approval prior to beginning the work. Traffic control shall follow the guidelines of Section 1-07.23 of the WSDOT/APWA Standard Specifications. All barricades, signs and flagging shall conform to the requirements of the MUTCD Manual. Signs must be legible and visible, with consideration for the horizontal and vertical curvature of the roadway and existing vegetation, and should be removed or covered at the end of each workday if not applicable after construction hours.
- B. Temporary Road Closures and Detours: The City may consider requests for full road closures where they are determined by the City Manager to be in the best interest of the public, and:
 - 1. A proposal for a road closure and a detour plan must be prepared and submitted to the City at least 20 working days in advance; said plan must be approved by the City Manager prior to closing any City street.
 - 2. The types and locations of the signs shall be shown on a detour plan.
 - 3. The applicant/contractor shall post "This Road Will Be Closed" signs, along with the anticipated dates and times of closure, a minimum of 10 days prior to the closing.

4. The applicant/contractor must notify, in writing, local fire, school, law enforcement authorities, Metro transit, adjacent parcels owners, and any other affected persons as directed by the City at least 10 days prior to roadway closer.
- C. Haul Routes: If the construction of a proposed development is determined by the City Manager to require special routing of large trucks or heavy construction equipment to prevent impacts to surrounding roads, residences or businesses, the applicant/contractor shall be required to develop and use an approved haul route.
1. When required, the haul route plan must be prepared and submitted to the City Manager and approved prior to beginning or continuing construction. The haul route plan shall address routing, hours of operation, signage and flagging, and daily maintenance.
 2. If the developer/contractor's traffic fails to use the designated haul route, the City Manager may prohibit or limit further work on the development until such time as the requirements of the haul route are complied with.
- C. Haul Road Agreement: When identified as a need by the SEPA review process or by the City, a haul road agreement shall be obtained by the applicant, franchised utility, developer, or property owner establishing restoration procedures to be performed upon completion of the haul operation.
- D. Pedestrian Circulation Plan: Where a development or construction activity will obstruct an existing pedestrian walkway, including formal sidewalk, maintained trail, worn (unmaintained) foot trails, shoulder, or other forms of pathway regularly used by pedestrians, a pedestrian circulation plan shall be required prior to beginning any construction activity. The pedestrian circulation plan must address alternative access routes to safely direct pedestrians travel in, around, or through a work area.
- a. Where existing pedestrian facilities exist outside the limits of the work zone, they may be utilized as the alternative pedestrian path provided that pedestrian connections with the existing pedestrian path can be made at safe and legal locations and appropriate signage is provided, in compliance with MUTCD, to direct pedestrian movements to the alternative routes.
 - b. Where existing pedestrian facilities cannot move pedestrians around a work zone, a temporary alternative pedestrian pathway must be provided and must be compliant with current ADA standards, including, but not limited to, temporary ramps where required and continuous cane-detectable barriers around the revised pedestrian route.
 - c. All barricades, signs and flagging shall conform to the requirements of the MUTCD Manual. Signs must be legible and visible and should be removed at the end of each workday if not applicable after construction hours.
- E. Bicycle Circulation Plan: Where a development or construction activity will obstruct, close, or create a hazardous condition of loose pavement or material on an existing marked bicycle lane or traffic lane marked with a sharrow symbol, a bicycle circulation plan shall be required prior to beginning any construction activity. The bicycle circulation plan must address signage to notify cyclists of the closure and/or hazardous condition, alternative access routes and detours for cyclists and signage notifying drivers on alternative access routes of the increased presence of cyclists during construction. All barricades, signs and flagging shall conform to the requirements of the MUTCD manual. Signs must be legible and visible, considering horizontal and vertical curves and overhanging vegetation, and should be removed or covered at the end of each workday if not applicable after construction hours.

4.10 Call Before You Dig

Contractors are responsible for timely notification of utilities in advance of any construction in right-of-way or utility easements as required under RCW 19.122. The utility One-Call Center phone number (1-800-424-5555) or 8-1-1 should be prominently displayed on the work site.

4.11 Utility Certification

All permits for new placement and replacement of existing utilities and utility structures shall be accompanied by written certification from the utility's professional engineer or from an agent authorized by the utility to certify that the installations conform to the appropriate standards, and that the proposed work is in conformity with sound engineering principles relating to street safety.

Section 5: Private Streets, Driveway, and Parking Design

All accesses to individual buildings or lots shall be located, designed, and constructed to balance multimodal transportation needs and maximize public safety on the street system. This chapter provides location and design criteria for access at the right-of-way line, access approaches in the right-of-way, private roads, and driveways or circulation roads internal to a private property.

5.01 General

- A. Each lot shall have direct access to a public right-of-way. If a project site is not immediately adjacent to the right-of-way access must be achieved by a recorded easement, or by a recorded access tract.
- B. The circulation system of developments shall intersect with existing and anticipated streets abutting the site at safe and convenient locations;
- C. Every lot upon which one or more building(s) is proposed to be erected or a traffic generating use is proposed to be established shall establish direct access from the street right-of-way as needed to provide public services such as fire protection, emergency service, mail delivery or trash collection.
- D. The designers of proposed developments must consider the access and driveway profile to ensure that required grade transitions can be complied with while considering building setbacks, terrain, and grades.
- E. All traffic control devices, including signs and pavement markings, shall meet the MUTCD standards.
- F. The use of alternative or pervious pavement materials is permitted, and generally encouraged, on private driveways, private roadways, and off-street parking areas.
- G. Access tracts and/or roadways required to provide access to two or more lots shall be developed to the width and standard required for its entire length. The practice commonly known as, or that yields the effect of, “telescoping” improvements (i.e., a street required to serve a short plat being reduced in width as the number of remaining lots decreases) is expressly prohibited.
- H. Any portion of a paved surface or any parking areas, driveways, and/or private roads located on private property, whether paved or not, shall be setback a minimum of 5’ from all property lines.
- I. The City may require additional connections for bicycles and pedestrians as directed by the City Manager as noted in Section 2.03.

5.02 State Highways

Access points to the state highway system are regulated through the Revised Code of Washington (RCW). The only state highway within the City of Kenmore is SR-522/Bothel Way NE and is classified as a “Managed Access Highway”.

Managed Access highways are those state highways where access rights have not been acquired by the state but access connections are regulated through the access management program. For more information, please visit the WSDOT Access Management website:

<http://www.wsdot.wa.gov/Regions/NorthCentral/planning/AccessMgmt.htm>

- A. Any development that requires the construction or improvement of a driveway or construction of a street that intersects a state or federal highway shall require a state right-of-way use permit from the City of Kenmore and shall be designed in accordance with this manual.
 - 1. This project must comply with all applicable State standards, as noted above, in addition to designing for City standards.

2. Where State or federal standards conflict with this manual and/or KMC, the more restrictive requirement shall prevail.

5.03 Private Streets

- A. Local access streets, which are to be privately owned and maintained, shall be built to the same local access standard as a public roadway as outlined in Section 6.
- B. Private streets shall be clearly distinguished and dedicated in an easement, tract, or right-of-way in a document recorded on title or on the face of the plat map to be recorded. Dedication language shall include a clear designation of maintenance responsibility for the improvements within the easement, tract, or right-of-way.
- C. Alleys, when appropriate, shall be designed to meet all of the following standards:
 1. Serve a maximum of 30 dwelling units
 2. Have a maximum length of 400 feet
 3. Connect two other streets (private or public); alleys cannot be dead-ends or cul-de-sacs and shall not intersect other alleys.
 4. In a dedicated tract or right-of-way with a minimum width sufficient to construct the alley and related grading. The minimum tract width shall not be less than 20 feet and shall be paved full width.
 5. The paved surface shall be sloped to the centerline of the alley and provide an inverted crown to control surface runoff as far from the buildings structures as feasible. Catch basins shall be provided in each alley to collect storm water prior to crossing any current or proposed walkways.
 6. Modifications to existing alleys serving commercial or industrial properties, in accordance with the above, will be determined on a case-by-case basis subject to approval by the City Manager.
- D. Private access tracts, when appropriate, shall be designed to meet all of the following standards:
 1. A private access tract shall serve a maximum of four (4) dwelling units.
 2. Minimum pavement width shall be 20 feet.
 3. Minimum tract width shall be 26 feet when adjacent to an existing property line; if not positioned along an existing property line the tract width may be reduced to 22 feet .
 4. Obstructions, such as walls, fences, poles, above ground utilities feature, shall be placed a minimum of 1 foot beyond the limits of the paved surface to maintain a minimum clearance of 20 feet.
 5. When located along an existing property line, the paved access shall be positioned within the tract to accommodate a 5-foot setback along the property line.
 6. Geometric design and profile shall meet the standards of a minor access road.
 7. If the length, measured from centerline of intersecting street to furthest extent of the tract exceeds 150 feet in length, a turnaround must be provided and approved by the Fire Marshal. A hammerhead turn-around is permitted for private roadways provided that the Fire Marshal approves the turnaround dimensions and layout.
 8. Paved surface shall be installed with an inverted crown (flow-line in the center) or sloped in one direction with a thickened edge or extruded curb to control surface runoff. Catch basins shall be provided in each private access tract to collect storm water prior to crossing any current or proposed walkways.

9. Additional easements may be required for utilities and drainage.
- E. Joint use driveways, when appropriate, shall be designed to meet all of the following standards:
1. A joint use driveway shall serve a maximum of two (2) dwelling units.
 2. Minimum pavement width shall be 14 feet.
 3. Minimum tract width shall be 20 feet when adjacent to an existing property line; if not positioned along an existing property line the tract width may be reduced to 15 feet.
 4. Obstructions, such as walls, fences, poles, above ground utilities feature, shall be placed a minimum of 1 foot beyond the limits of the paved surface to maintain a minimum clearance of 14 feet.
 5. When located along an existing property line, the paved access shall be positioned within the tract to accommodate a 5-foot setback along the property line.
 6. The length, measured from centerline of intersecting street to furthest extent of paved tract, shall not exceed 150 feet in length.
 7. Paved surface shall be installed with an inverted crown (flow-line in the center) or sloped in one direction with a thickened edge or extruded curb to control surface runoff. Catch basins shall be provided in each private access tract to collect storm water prior to crossing any current or proposed walkways.
 8. Driveway profiles and elevations shall comply with the intersection grade requirement per Section 7-06.
 9. Additional easements may be required for utilities and drainage.

5.04 Driveways

This section provides driveway standards for connections to public and private roads. It is not the intent of these Standards to govern design or location of driveways on private property except where they connect to the street right-of-way and where minimum setbacks are required along property lines. However, fire access requirements governed by the Fire Code (KMC 15.10) and KMC Title 18, establish criteria for driveway widths. No new driveway connection shall be constructed which does not conform to this chapter and minimum sight distance criteria established in Section 6.06 and Section 6.07.

A. Residential Driveways:

1. New driveways installed on roadways with an amenity zone shall generally comply with Figure 5-001 in Appendix B. The sidewalk shall be designed to match the roadway slope along the gutter flow line and all elevation changes required for the driveway to meet road grade, shall be accomplished in within the limits of the amenity zone.
2. New driveways installed on roadways where no urban-type frontage improvements exist, and are not required, shall generally be designed and constructed to comply with KCRS Figure 3-003.
3. New driveways installed on roadways with existing urban frontage improvements without an amenity zone shall generally be designed and constructed to comply with KCRS Figure 3-005 and shall maintain a minimum 5 feet pedestrian path which continues at straight-line grade matching the sidewalk on either side unless otherwise approved by the City Manager.
4. Shall have a minimum width of 10 feet and a maximum width of 20 feet within, or at, the right-of-way, access easement, access tract, or other area of shared access.
5. Shall be continuously paved or surfaced with gravel between the public right-of-way and the parking area require by KMC 18.40.030, unless otherwise approved by the City of Kenmore.

- i. This requirement shall not restrict the use of alternative pavement types (such as porous pavements or pavers) and methods (such as wheel strips) to meet flow control BMP or Low Impact Development requirements.
- ii. Driveways with a slope exceeding 5% in grade shall be paved; gravel surfacing will not be permitted on steep driveways.

B. Commercial & Multi-Family Driveways:

1. New driveways installed on roadways with an amenity zone shall generally comply with Figure 5-001 in Appendix B. The sidewalk shall be designed to match the roadway grade and all elevation changes for the driveway to meet road grade, shall be accomplished in within the limits of the amenity zone.
 - i. Driveways in sections that require an 8 foot or 10 foot wide sidewalk, shall utilize this detail for construction except that the 'amenity zone' shall be considered the 4 foot wide strip of sidewalk immediately adjacent to the back of curb; the pedestrian route shall be maintain in the back 4 to 6 feet of the sidewalk.
2. New driveways installed on roadways without an amenity zone shall generally be designed and constructed to comply with KCRS Figure 3-005 and shall maintain a minimum 5 feet pedestrian path which continues at straight-line grade matching the sidewalk on either side unless otherwise approved by the City Manager.
3. Shall have a minimum paved width of 24 feet a maximum paved width of 36 feet.
4. Shall be continuously paved between the public right-of-way and the parking area require by KMC 18.40.030, unless otherwise approved by the City of Kenmore.
 - i. This requirement shall not restrict the use of alternative pavement types (such as porous pavements or pavers) and methods (such as wheel strips) to meet a flow control BMP or Low Impact Development requirement.
5. For commercial or industrial driveways with heavy traffic volumes or significant numbers of trucks, the City may require construction of the access as a road intersection and/or may require additional reinforcement within the driveway section. This requirement will be based on traffic engineering analysis submitted by the applicant that considers, among other factors, intersection spacing, sight distance, and traffic volumes.

C. New Driveway Requirements:

1. New driveway connections will require a street right-of-way use permit or engineering permit, as appropriate, issued by the City prior to beginning construction within the right-of-way.
2. New driveways must be a minimum length of 20 feet, measured along the driveway centerline between the nearest tract/easement/right-of-way line of a shared access or roadway and the nearest edge of the parking area/carport/garage required per KMC 18.40.030.
3. New driveways shall intersect the approach street at an angle between 85° and 95° and shall maintain this requirement for the all portions of the driveway which lie within a public right of way, unless otherwise approved by the City Manager. Exceptions may be granted for driveways within the limits of a cul-de-sac bulb.
4. All driveways must be paved within the limits of the public right of way
5. Driveway profiles and elevations shall comply with the intersection grade requirement per Section 7-06.
6. Driveways directly giving access onto arterials may be denied if alternate access is available.

7. All abandoned driveway areas on the same frontage shall be removed, and the curbing and sidewalk or shoulder and ditch section shall be properly restored.
8. Maintenance of driveway approaches, including any regulatory signage or striping, shall be the responsibility of the owner whose property they serve.
9. The City and franchised utilities are not obligated to replace alternative surfacing material within the public right-of-way with a like material and may, at the City Manager's discretion, replace existing driveways with standard asphalt or concrete within the right-of-way.
10. Grade transitions, excluding the tie to the roadway, shall be constructed as smooth vertical curves. The maximum change in driveway grade within the right-of-way shall be 8 percent within any 10 feet of distance on a crest and 12 percent within any 10 feet of distance in a sag vertical curve. Whenever there is a potential for future roadway widening, the driveway shall be graded to match the future widened road section without encroachment into the sidewalk.
11. For driveways crossing an open ditch section, culverts shall be adequately sized to carry anticipated storm water flows and at a minimum the culvert shall be equal to or larger than any existing pipes within 500 feet upstream or downstream; in no case shall the minimum pipe size be less than 12-inch in diameter. Pipe should be long enough to account for the driveway side slopes and shall be installed with a 3:1 beveled end on either side and a trash rack on the upstream side. The property owner making the installation shall be responsible for determining proper pipe size. The City may require the owner to verify the adequacy of pipe size.
 - i. Additional requirements will apply when the driveway crosses a classified stream per KMC 18.55 including, but not limited to, requirements for a *Hydraulic Permit Approval* (HPA) from WDFW.
12. Storm drainage from driveway surfaces must be accounted for in the roadway drainage design.
13. Surface water from new driveway surfaces shall not be permitted to flow across any public walkway.

D. Location of New Driveways.

1. Driveway location is subject to City approval.
2. No portion of driveway width shall be allowed within 5 feet of side property lines.
 - i. Exceptions may be granted without a formal variance request for access panhandles and for lots taking access from a cul-de-sac bulb; in such cases the driveway shall be located, and possibly reduced in width, to provide the largest setback feasible.
3. No two driveways along a public right-of-way shall be closer together than 18 feet where it intersects with the street right-of-way line.
 - i. Exceptions may be granted without a formal variance request for access panhandles and for lots taking access from a cul-de-sac bulb; in such cases the driveway shall be located, and possibly reduced in width, to provide the largest separation feasible.
4. On frontages 75 feet or less, no more than one driveway per lot shall be constructed. On frontages over 75 feet, the City may permit two or more driveways per lot, subject to City Manager approval.
5. Project sites which have multiple frontages, such as corner lots, must take access from the street with a lower classification unless no other feasible alternative exists; for this standard, removal of existing improvements or obstruction such as walls, fences, or existing utilities shall not be sufficient to determine an access infeasible.
6. Driveways shall not be allowed within an existing or planned intersection radius return and shall

be positioned as far from an intersection as feasible.

7. Notwithstanding any other provisions, driveways will not be allowed where they are prohibited by separate City Council action or where they are determined by the City to create a hazard or impede the safe operation of traffic on the roadway.
- E. For land development projects and/or changes in use, existing driveway connections which do not conform to this chapter shall be reconstructed to the requirements for new driveways.

5.05 Parking Lots

- A. Parking lots, including the amount of required off-street parking stalls, stall dimensions, and drive isle dimensions and layout, shall be designed and constructed in compliance with KMC 18.40.
1. On-street parking stalls located within or requiring turning movements within, the public right-of-way shall not be counted toward the required number of off-street stalls except as permitted by KMC 18.29.070. Where on-street parking or parking within the right-of-way is to be counted toward the parking requirement, the parking stalls shall:
 - i. Comply with the dimension requirements of KMC 18.40, and
 - ii. Be located in outside of existing or future vehicle travel lanes, and
 - iii. May require additional pavement width in excess of the minimum widths listed in these Standards.
- B. The number of ADA compliant parking stalls provided on each site shall comply with KMC 18.40.060 and current ADA standards.
- C. Where off-street parking stalls and drive isles are separated from the public right-of-way, roadways providing access to the off-street parking area shall meet the standard of a Minor Commercial Access street including the requirement for a pedestrian walkway.

Section 6: Street Design

This chapter sets the minimum standards for geometric street design of public roadways, commercial roadways, and private roadways where notes.

6.01 Reconstruction

- A. Reconstructed, altered, widened, or improved roadways shall be brought into compliance with these standards.
- B. For the purposes of this section, utility installations alone shall not be considered reconstruction but must still meet the standards and requirements of Section 11.
- C. Transitions or tapers necessary to connect with existing roadways of a different width shall meet AASHTO and MUTCD standards.

6.02 Applicable Standards

- A. Projects adjacent to an existing roadway shall improve the existing roadway to the current standard for its existing classification per Section 6.03, 6.04, or 6.05, except where project impacts result in a reclassification of the roadway.
- B. Projects adjacent to existing roadways in which the project impacts, or changes to the number of units served, result in the change in the roadway classification as noted below shall be required to improve the entire roadway to the current standard for the new classification. Limits of the roadway upgrade shall be determined by the City.
- C. Subdivision and residential projects shall construct internal roadways per Section 6.04 or Section 5.03.
- D. Commercial, industrial, and residential apartment projects shall construct internal roadways per Section 6.05. The classification of new internal roadways for these types of project shall be determined by the City.
- E. Town home developments shall construct internal roads providing access to parking areas as a minor multifamily access road per Table 6.2 and Section 6.05, except that the required 5 foot sidewalk can be relocated as needed to provide pedestrian access to the main entrance of each unit.
- F. Alternative road designs may be proposed on any road type when approved by the City manager. Alternative roadway sections shall follow the guidance of Section 6.12.

6.03 Typical Sections for Existing Arterials and Collector

Existing roadways which are classified as neighborhood connections (neighborhood collector) or higher, and are identified in the City's comprehensive plan, shall be improved to the configuration and width as shown in the appropriate Figure in Appendix 'A'. A copy of the City's layered network map is also included in Appendix 'A'. See Section 9 for pavement design requirements.

6.04 Typical Sections for Residential Access Roads

- A. Internal roadways for residential and plat projects shall be constructed to the general widths provide in Table 6.1., unless otherwise approved by the City Manager
- B. Vertical curbing is required on the both sides of all roadway types unless a half-width improvement is permitted, in which case a vertical curb and gutter shall be provided on the near side only.

- C. Vertical curbing shall be constructed per Sections 8.02, 8.03, and 8.04.
- D. On local access streets, sidewalk is required on any side of the road which will be adjacent to newly created lots, structures, or driveways; in no case shall a road be constructed without sidewalk on at least one side.
 - 1. Driveways for maintenance access roads, required solely for utility or storm water maintenance, shall not trigger the sidewalk requirement.
 - 2. New roadways where new lots, structures, or driveways are only proposed on only a portion of one-side of the street, the sidewalk requirement shall be applied to the entire length of proposed roadway out to the nearest intersecting roadway of equal or higher classification.
 - 3. Projects which are adjacent to existing roadways meeting these roadway classifications and which do not result in change in the roadway classification, shall provide sidewalk on the near side of the roadway
 - 4. Additional walkways may be required for roadways which are identified as priority pedestrian routes or Safe Routes to School.
- E. All collector roadways shall provide sidewalk on both sides as noted in Table 6.1
- F. Sidewalk shall be constructed per Sections 8.01, 8.03, and 8.04.
- G. Amenity zones, per Section 8.10, are required between the curb and sidewalk in any location where new sidewalk is proposed or required on residential access roads.
- H. Half-street Improvements: Where a proposed roadway is adjacent to an undeveloped parcel, the road shall be sized to accommodate future development on the adjacent parcel(s). Only in the case that the anticipated use of the adjacent site increases the residential roadway classification which would have otherwise been required for the immediate or initial project, the developer shall be permitted to improvement the roadway to a half-street standard. The half-street standard shall:
 - 1. Require a minimum pavement width of 20'
 - 2. Maintain a minimum 5' setback between the edge of pavement and adjacent property line.
 - 3. Permit the roadway to be temporarily developed without a crown so that all stormwater can be collect, conveyed, and mitigated on the near side of the street.
- I. In the case that a project develops next to a roadway previously constructed to the half-street standard, the project shall be required dedicate any additional right-of-way to meet the full roadway standard, saw cut the pavement at the future right-of-way centerline, establish a typical crown at right-of-way center, and shall construct all required elements on the near side of the right-of-way centerline.
- J. Collectors intersecting with boulevards, arterials, or neighborhood connection roads shall be 32 feet wide for the first 150 feet. Total improvement and right-of-way widths shall be adjusted accordingly.
- K. In no case, shall a vehicle travel way be built within 5 feet of a property line for residential or plat projects.
- L. Roadway striping shall be clearly shown on the project construction drawings and shall be reviewed by the City prior to construction of the roadway improvements. Striping shall be designed to maximize traffic calming opportunities while maintaining on-street parking to the maximum extent feasible.
- M. Parking restrictions shall be consistent with Table 6.1 except where otherwise directed by the City. Where parking restrictions are required, the applicant shall furnish and install "no parking" signs in compliance with MUTCD.
- N. See Section 9 for pavement design and material requirements.

Table 6.1: Residential Access Roads

Road Type	Collector	Local Access	Private Access
General Description	Providing access to a large number of lots and/or multiple developments; adjacent property owners may not be the primary users.	Generally providing access to a fixed number of lots; adjacent property owners are typically the primary users.	Generally providing access to a fixed number of lots; adjacent property owners are typically the primary users.
Public or Private	Public	Public	Private
Number of Lots/ Dwelling Units	Over 50	50 Maximum	4 Maximum
Design Speed¹	30 mph	25 mph	15 mph
Maximum Grade	15%	15%	15%
Minimum Pavement Width (Curb to Curb)	28 feet ²	20 feet	18 feet
Total Improvement Width (Back of walk to back of walk)	47 feet ²	39 feet	18 feet
Total Right-of-Way Width	48 feet ²	40 feet	24 feet (may be reduced to 20' when not adjacent to property line)
Sidewalk Requirement	Both Sides	Each side with proposed lots/structures (one side minimum)	None
Minimum Sidewalk Width	5 feet	5 feet	N/A
Amenity Zone Requirement	Both Sides	Any side with a sidewalk	None
Minimum Amenity Zone Width	4 feet	4 feet	N/A
Min. Half-street Pavement Width³	20 feet	20 feet	N/A (Full section required)
Min. Half-street ROW Width³	35 feet	35 feet	N/A (Full section required)
Curb Type	Vertical	Vertical	As needed for drainage
Striping⁴	Fog lines (only)	None	None
Parking Restrictions⁵	One side	One side	Both Sides
Typical Lane Width⁴	10 feet	10 feet	N/A

- 1 The design speeds listed are a basis for determining geometric elements and does not imply posted or legally permissible speed.
- 2 Additional roadway width is required near intersections with boulevards, arterials, or neighborhood connection roads per Section 6.04.J.
- 3 Minimum half-street improvements, or minimum required improvements, are only permitted per Section 6.04-H.
- 4 Striping shall be as directed by the City in compliance with Section 6.04.L.
- 5 Parking restrictions are general recommendation subject to City review; signage is require in compliance with Section 6.04.M

6.05 Typical Sections for Commercial Access Roads

- A. Internal roadways for commercial, industrial, and multi-family projects shall be constructed to the general widths provide in Table 6.2., unless otherwise approved by the City Manager.
- B. Vertical curbing is required on the both sides of all roadway types.
- C. Vertical curbing shall be constructed per Sections 8.02, 8.03, and 8.04.
- D. On roadways classified as commercial/major multi-family access streets, sidewalk is required on any side of the road which will be adjacent to newly created lots, structures, or driveways; in no case shall a road be constructed without sidewalk on at least one side.
 - 1. Driveways for maintenance access roads, required solely for utility or storm water maintenance alone, shall not trigger the sidewalk requirement.
 - 2. Where new lots, structures, or driveways are only proposed on a portion of one-side of the street, the sidewalk requirement shall be applied to the entire length of proposed roadway out to the nearest intersecting roadway of equal or higher classification.
- E. Sidewalk shall be constructed per Section 8.01, 8.03, and 8.04.
- F. All pedestrian crossings on internal commercial access roads shall be designed and constructed as speed tables which provide an elevated crossing for pedestrians.
 - a. Speed tables shall be treated with colored concrete, pavers or other visual cues to the presence of the table and crosswalk.
 - b. If for any reason, a speed table is permitted to be asphalt, it shall be marked per MUTCD standard, Option B, for markings in both directions on both sides of the table.
- G. Industrial/Limited Commercial Access roads shall be constructed with at least one sidewalk, regardless of driveway locations.
- H. Amenity zones, per Section 8.10, are required between the curb and sidewalk on Industrial/Limited Commercial Access roads.
- I. Industrial/Limited Commercial Access roads intersecting with boulevards, arterials, or neighborhood connection roads shall be 32 feet wide for the first 150 feet. Total improvement and right-of-way widths shall be adjusted accordingly.
- J. Commercial/Major Multi-family Access roads intersecting with arterials may be required to provide 32 feet of pavement width for the first 150 feet as determined by the City. Total improvement and right-of-way widths shall be adjusted accordingly.
- K. Vehicle travel ways shall not be built within 5 feet of a property line unless otherwise approved by the City Manager.
- L. Roadway striping shall be clearly shown on the project construction drawings and shall be reviewed by the City prior to construction of the roadway improvements. Striping shall be designed to maximize traffic calming opportunities while maintaining on-street parking to the maximum extent feasible.
- M. Parking restrictions shall be consistent with Table 6.2 except where otherwise directed by the City. Where parking restrictions are required, the applicant shall furnish and install “no parking” signs in compliance with MUTCD.
- N. See Section 9 for pavement design and material requirements.

Table 6.2: Commercial Access Roads

Road Type	Industrial / Limited Commercial Access	Commercial / Major Multi-Family Access	Minor Multi-Family Access
General Description	Providing access to businesses which generally do not require interaction with the general public; roadway design driven primarily by delivery or commercial/ industrial vehicle types	Providing access for all modes or transportation directly to businesses or larger multi-family housing which include multiple buildings, usually on multiple side of the proposed roadway.	Generally providing access to a fixed number of lots; adjacent property owners are typically the primary users.
Public or Private	Public or Private	Public or Private	Private
General Thresholds⁴	Limited driveways and pedestrian access needs.	Public businesses along roadway or larger multi-family project/site with pedestrian access to building typically needed on more than one side	Single multi-family project/site; pedestrian access to building typically limited to one side
Design Speed¹	30 mph	25 mph	15 mph
Maximum Grade	15%	15%	15%
Minimum Pavement Width (Curb to Curb)	30 feet ²	24 feet ²	20 feet
Total Improvement Width (Back of walk to back of walk)	41 feet ²	35 feet ²	26 feet
Total Right-of-Way Width	46 feet ² (may be reduced to 42' when not adjacent to property line)	36 feet ²	31 feet (may be reduced to 26' when not adjacent to property line)
Sidewalk Requirement	One-side (generally on opposite side of primary driveways)	Each side with proposed lots/structures (one side minimum)	One side (same side as building/structure)
Minimum Sidewalk Width	6 feet	5 feet	5 feet
Amenity Zone Requirement	One side (same side as sidewalk)	None	None
Minimum Amenity Zone Width	4 feet	N/A	N/A
Curb Type	Vertical	Vertical	Vertical or Rolled
Striping³	Per City direction (additional traffic control measures may be required)	Per City direction (additional traffic control measures may be required)	Per applicant design
Parking Restrictions⁴	None	One side	Both Sides
Typical Lane Width⁴	10 feet	10 feet	N/A

1 The design speeds listed are a basis for determining geometric elements and does not imply posted or legally permissible speed.

2 Additional roadway width may be required near intersections with boulevards, arterials, or neighborhood connection roads per Sections 6.05.I & 6.05.J.

3 Striping shall be as directed by the City in compliance with Section 6.05.L.

4 Parking restrictions are general recommendation subject to City review; signage is require in compliance with Section 6.05.M

6.06 Stopping Site Distance

- A. Stopping Sight Distance (SSD) is the sum of two distances: the distance traveled during perception and reaction time and the distance required to stop the vehicle. The perception and reaction time used in design is 2.5 seconds. The stopping sight distance is calculated using a constant deceleration rate of 11.2 feet/second².
- B. When calculating stopping sight distance, use $h_1 = 3.50$ feet and $h_2 = 0.50$ foot. Available stopping sight distance is calculated for a passenger car using an eye height of 3.50 feet and an object height of 0.50 foot. Although AASHTO allows a 2-foot object height, a 0.50-foot object height is used because objects with a height between 0.5-foot and 2 feet may be perceived as hazards that would likely result in an erratic maneuver. The grade of the roadway has an effect on the vehicle's stopping sight distance. The stopping distance is increased on downgrades and decreased on upgrades. When evaluating sight distance with a changing grade, use the grade for which the longest sight distance is needed. Road grades other than those shown in Table 6.3 must be interpolated.
- C. Sag vertical curves on residential or commercial streets that do not meet the minimum SSD may be approved by the City Manager if no practical design exists and if acceptable illumination is provided throughout the curve and is maintained by a franchised utility. Illumination shall be per Section 8.11.

Table 6.3: Stopping Site Distances

Minimum Site Distance Required (ft)							
DESIGN SPEED (MPH)	No Slope	3% Down	6% Down	9% Down	3% Up	6% Up	9% Up
55	495	520	553	594	470	450	433
50	425	446	474	507	405	388	375
45	360	378	400	427	344	331	320
40	305	315	333	354	289	278	269
35	250	257	271	287	237	229	222
30	200	205	215	227	200	184	179
25	150	158	165	173	147	143	140

6.07 Entering Site Distance (ESD)

- A. Specific ESD values for required design speeds are listed in Table 6.4
- B. Entering vehicle eye height is 3.5 feet, measured 10 feet back from edge of traveled way and ten feet back from face of curb on urban roadways. Approaching vehicle height is 4.25 feet.
- C. Requirements in this section and Table 6.4 apply to an intersection or driveway approach to a typical road under average conditions. In difficult topography the City Manager may authorize a reduction in the ESD based on factors mitigating the hazard. Such factors may include an anticipated posted or average running speed less than the design speed or the provision of acceleration lanes and/or a median space allowing an intermediate stop by an approaching vehicle making a left turn.
- D. Where a significant number of trucks will be using the approach road, the City Manager may increase the entering sight distance requirements by up to 30 percent for single-unit trucks and 70 percent for

semi-trailer combinations.

Table 6.4: Entering Site Distances

Design Speed (mph)	30	35	40	45	50	55	60
Entering Sight Distance (Ft.) ^{1 2 3}	335	390	445	500	555	610	665

¹ Entering sight distance shown is for a stopped passenger vehicle to turn left onto a two-lane arterial with no median and grades 3 percent or less. For other conditions the time gap should be adjusted and required sight distance recalculated. (See 2001 AASHTO – Intersection Control section).

² For multilane roadways: For left turns onto two-way arterials with more than two lanes, add 0.5 seconds for passenger cars or 0.7 seconds for trucks for each additional lane from the left, in excess of one, to be crossed by the turning vehicle.

³ For minor and approach grades: If the approach grade is an upgrade that exceeds 3 percent; add 0.2 seconds for each percent grade for left turns.

6.08 Horizontal Curve Criteria

- A. The minimum centerline radius on non-arterial streets shall be as shown in Tables 6.5
- B. Super-elevation is not required in the design of horizontal curves on residential access streets.
- C. Should the re-design of an existing arterial or construction of a new arterial be needed, the horizontal curvature shall be design by the project engineer in accordance with current AASHTO Standards.

Table 6.5: Minimum Radius Design Values

Design Speed (mph)	25	30	35
Minimum Radius (Ft.)	180	300	460

6.09 Vertical Alignment

- A. Maximum roadway grades on all streets shall not exceed 15% maximum.
- B. Maximum roadway grade may be exceeded for short distances of 300 feet or less, upon showing that no practical alternative exists. Grades greater than 15 percent that exceed the 300-foot distance must be approved by the City Manager through the road variance process. Additionally, the maximum grade shall not exceed 15 percent unless verification is obtained from the Fire Marshal that additional fire protection requirements will be met and the applicant’s engineer must demonstrate what method will be used to ensure drainage will be controlled. Grades exceeding 12 percent shall be paved with hot mix asphalt (HMA) or portland cement concrete (PCC) as determined by the City Engineer.
- C. Grade transitions shall be constructed as smooth vertical curves, without angle points, except in intersections where the difference in grade is one percent or less and upon approval of the City Manager.

6.10 Street Ends

Any street, public or private, which extends more than 150 feet from the centerline of the accessing street to farthest extent of surfaced traveled way requires an approved turnaround.

- A. Hammerheads: A hammerhead turn around may be used to satisfy the turnaround requirements for private streets only.

1. Final hammerhead dimensions and layout shall require Fire Marshal approval.
 2. The minimum inside radius shall be 20 feet.
 3. Each leg of the hammerhead shall be a minimum length of 24 feet, measured from the intersection of the centerlines for each leg.
- B. Permanent Cul-de-sac Bulbs: A cul-de-sac bulb is the required turn-around type for any public roadway and shall be constructed as follows:
1. Minimum right-of-way diameter across bulb section: 100 feet in a permanent cul-de-sac; right-of-way may be reduced, provided utilities and necessary drainage are accommodated on permanent easements within the development.
 2. Minimum diameter of surfacing or pavement across bulb: 80 feet of paving.
 3. The City may require an emergency vehicle access and/or an off-street walkway to connect a cul-de-sac at its terminus with other streets, parks, schools, bus stops, or other pedestrian traffic generators.
 4. The City may require signage to be installed within the bulb to restrict parking and maintain emergency access.
 5. The maximum cross slope in a bulb shall not exceed 6 percent in any direction.
- C. Temporary Cul-de-sac Bulbs: If a street temporarily terminates at a property boundary, serves or will serve more than four (4) lots, and is longer than 150 feet, a temporary bulb shall be constructed near the development boundary.
1. A temporary public easement shall be provided for the bulb area lying outside the typical right-of-way.
 - i. Temporary cul-de-sac easements shall be extinguished once the proposed street extension is constructed and approved by the City.
 - ii. The applicant /developer will be responsible for preparing the necessary documentation to extinguish the easement.
 2. The paved bulb shall be 80 feet in diameter with sidewalks terminated at the point where the bulb radius begins.
- D. Removal of the temporary constructed cul-de-sac, restoration of landscaping, and construction of the extension of the sidewalk shall be the responsibility of the applicant/developer who extends the road.
- Cul-de-sac Islands: A cul-de-sac island will not be permitted unless it is included as a flow control BMP, LID feature, or other surface storm water facility which will be maintained as a storm water facility by the City or a homeowners association. If an island is proposed, the full limits of the paved cul-de-sac bulb shall be sloped toward the island and all runoff shall enter to island area without the need for additional storm drain inlets within the paved limits.

6.11 Traffic Calming Devices

Wherever necessary for the safe operations of multi-modal transportation, or to address existing or anticipated speed concerns as determined by the City Manager, the City may request that the applicant include traffic calming measures on newly constructed or altered roadways.

- A. **Speed Humps:** May be required where there are concerns of speeding.
1. Speed humps shall generally be designed, constructed, and marked/painted per Figure 6-001 in Appendix B

2. Considerations for drainage shall be applied where proposed speed humps obstruct the existing or natural flow of surface water.
 3. Speed humps which cross an existing or proposed walkway shall be modified to maintain a pedestrian pathway which is ADA compliant.
 4. Speed humps which cross an existing or proposed bicycle lane shall be modified to provide appropriate consideration for bicyclists.
 5. Speed *bumps*, identified as those devices with widths along the direction of travel of between 1 and 3 feet, are not permitted unless written justification for their use due to site restrictions is provided to the City and is approved by the City Manager.
- B. **Chicanes:** May be required where there are concerns of speeding and/or as part of an alternative roadway design. They may also be requested at or near pedestrian crossings to improve pedestrian safety.
1. Chicanes shall be uniquely designed for each site to address emergency access concerns and shall be approved by the Fire Marshal prior to construction of the improvements.
 2. Considerations for drainage shall be applied where proposed chicanes obstruct the existing or natural flow of surface water.
 3. Chicanes which cross an existing or proposed walkway shall be modified to maintain a pedestrian pathway which is ADA compliant.
 4. Chicanes which cross an existing or proposed bicycle lane shall be modified to provide appropriate consideration for bicyclists.
- C. **Traffic Circles:** Or mini-roundabouts may be required where traffic impacts are determined to negatively affect an intersection or where existing sub-standard intersections will be subject to an increase in traffic. The impacts evaluated for implementation of traffic circles may exceed the typical *Level of Service* evaluation and shall include safe movements for all users of the intersection including pedestrians, bicyclist, personal vehicles, anticipated transit vehicles, anticipated freight vehicles, and emergency services vehicles.
1. Traffic circle shall be uniquely designed for each site but shall generally follow the guidelines of the *WSDOT Design Manual* Chapter 1320.
- D. **Speed Tables:** Or raised crosswalks may be required in priority pedestrian areas or where an elevated level of pedestrian safety is desired. In some unique cases, the City may request that an entire intersection be raised; the raised intersection shall generally be designed with the same guidelines.
1. Speed tables are required on all pedestrian crossings on all internal commercial access roads.
 2. Speed tables shall generally be designed and constructed per Figure 6-002 in Appendix B
 3. Speed tables must be a constructed of a material which is of different color and texture than the drive isle it crosses; if concrete is used on the top (flat) portion of the table, it must be stamped and/or textured with a pattern more distinguishable than standard brushing.
- E. **Additional Pedestrian Accommodations:** At mid-block crossings and at intersections which have been identified as priority pedestrian routes, the City may require additional pedestrian accommodations including, but not limited to, rectangular rapid-flashing beacons (RRFB), pedestrian refuge islands, and curb extension or pinch points.
1. When an RRFB is required, the system shall be solar power and shall flash in both directions of vehicle travel. The final system shall be approved by the City prior to installation.
 2. When pedestrian refuge islands or curb extensions are required, areas which are not part of the pedestrian travel way shall surfaced with stamped concrete using a stamp pattern approved by

the City, unless an alternative solution, such as an agreed upon landscaping plan, is otherwise approved by the City Manager.

6.12 Alternative Road Design Guidelines

Where specific projects can be better served by alternative road design elements such as shared spaces, living streets/Woonerf, cycle tracks, green alleys, and parklets the applicant and City staff shall coordinate the alternative design elements to promote the use of such designs in a manner that adequately addresses the safety concerns of the City. Some basic guidelines for some alternative design types have been provided below but these guidelines do not provide all of the detail needed for full construction and implementation of such designs; the project engineer must provide a unique design for such roadway types. Generally, alternative roadway designs shall be privately maintained unless otherwise approved by the City Manager.

- A. **Living Streets:** The Living Street, shared-space roadway, or “woonerf” involves creating a street which is shared among pedestrians, bicyclists, and motor vehicles; pedestrians have priority over cars. The street is designed without a clear division between pedestrian and auto space (i.e., no continuous curb), so motorists are forced to slow down and travel with caution. The street is lined with street furniture (e.g., planters, street trees, benches), parking areas, and areas for social interaction to help reduce vehicles speeds but also to promote greater use of the shared space. The end result is a street which is a livable and attractive environment for a variety of activities.
1. For streets which permit only one direction of travel, a minimum vehicle clearance of 10 feet shall be maintained, unless otherwise approved by the City Manager.
 2. For streets which allow two directions of travel, a minimum vehicle clearance of 16 feet shall be maintained, unless otherwise approved by the City Manager.
 3. The roadway must not include a continuous above grade curb.
 - i. Short curb sections may be used in association with the required physical features noted below.
 - ii. A sunken curb or other method of distinguishing the surfaces available to vehicle travel may be required to meet current ADA guidelines.
 4. The roadway must be paved with an alternative pavement type which differs in color and texture from the adjacent roadway and sidewalks; concrete, if proposed must be colored and stamped with a pattern more distinguishable than standard brushing. Pervious pavers are an acceptable alternative pavement type for such a use.
 5. Physical features such as street furniture, parking stalls, play areas, art, bike racks, and other constructed element shall be provided on alternating sides of the roadway so that the minimum vehicle clearance is not exceeded for more than 50 continuous feet, unless otherwise approved by the City Manager.
 - i. The required physical features shall create a shift in the vehicle clear area between 1/3 and 1/2 of the total vehicle clearance width, unless otherwise approved by the City Manager. (I.E. If a vehicle lane is 16’ wide, the travel lane centerline must shift by 5.3’ minimum and 8’ maximum).
 - ii. The required physical features, including parking stalls, shall be rotated in use so that the same physical feature is not provided in consecutive locations along the roadway, unless otherwise approved by the City Manager.
 - iii. Trees must be provided at minimum of 1/4 of the required roadside features.

6. The roadway must maintain a minimum “comfort zone” of 4 feet on each side. The comfort zone is the area beyond the limits of a straight line drawn along the outer limits of the vehicle path (farthest vehicle travel point on each side).
7. The roadway must include a sign at each entrance to a public roadway which states that the roadway is a shared space or living street; the sign shall be approved by the City prior to installation.
8. The roadway must include lighting features which are designed to provide a minimum of 1.5 foot-candles to all portions of the roadway and physical features with an average-to-minimum uniformity ratio of 3:1; the comfort zone need not be assessed for lighting.
9. Where parking stalls are provided within a living street, they may be counted toward the required minimum parking per KMC 18.40, provided that turning movements into the public right-of-way are not required to enter/exist the stall.

Section 7: Intersection Design

The design criteria in this chapter apply to street intersections. Intersections, as applied in this chapter, shall not include individual residential driveways or joint-use driveways, but shall include all other roadway types, both public and private.

As much as possible, intersection design shall conform to the guidelines set forth in AASHTO Policy on Geometric Design. For state highways, refer to WSDOT design manual(s).

7.01 Alignment

The angle of an intersection of two streets or a driveway with a street shall be between 85° and 95° and must maintain this angle a minimum of 10 beyond the right of way or easement line, unless otherwise approved by the City Manager. Exceptions may be granted for driveways within the limits of a cul-de-sac bulb.

7.02 Spacing

Spacing between adjacent intersecting streets, whether crossing or T-connecting, shall be as shown in Table 7.1.

Table 7.1

When highest classification involved is:	Minimum centerline offset shall be:
Boulevard or Arterial	500 feet
Neighborhood Connection	300 feet
Urban Avenue	150 feet
Any lesser street classification	100 feet

7.03 Design Vehicles

- A. Intersections shall be designed to accommodate the design vehicle appropriate for the highest classified street forming the intersection.
- B. The intersection design shall accommodate the use of the roadway as a designated truck route, bus route, or school bus route, where appropriate.
- C. The minimum design vehicle is the SU-30, although use of larger design vehicles may be required depending on roadway classification, transit routes, and adjacent land use.
- D. All elements of the intersection shall be designed so the design vehicle will not encroach onto sidewalks, walkways, landscaped areas, or the opposing travel lane.
 1. Improvements associated with traffic calming devices or alternative roadway designs may be designed with mountable curbs provided that the area is not part of a pedestrian pathway and is a paved surface.
 2. Improvements associated with traffic calming devices or alternative roadway designs may be designed such that they result in temporary movements into the opposing traffic lane, provided that appropriate transitions and signage are provided.

7.04 Curb Radii

- A. Curb radii design must balance vehicle turning movements with pedestrian safety. Typically, it is appropriate to use the smallest turn radii possible that still accommodates the design vehicle.
- B. Curb radii are not required for individual driveways (commercial or residential), alleys, joint-use driveways, and private access streets.
- C. For design, round curb radii to the nearest five foot increment.
- D. Typical curb radii based on street classification are shown in Table 7.2. However, these values may be impacted by site conditions, including width of receiving lanes, on-street parking, and angle of intersecting roadways.
- E. A proposal for a curb radius design must be accompanied by supporting documentation for review and approval by the City.

Table 7.2

Street Classification (for highest street classification at intersection)	Radius (feet)
Boulevard or Neighborhood Connection to Boulevard or Neighborhood Connection	35
Boulevard or Neighborhood Connection to Local Street	25
Local Street to Local Street	20
Transit/Truck Route	30

7.05 Drainage

- A. An intersection shall be laid out and graded so that surface water drains and the intersection is safe and accessible for pedestrians and bicyclists.
- B. Drainage structures shall not be placed in an ADA ramp, landing, or crosswalk area.
- C. Drainage structures should be located outside the corner radii to the maximum extent feasible.
- D. Drainage structures should be placed at upstream side of existing or proposed curb return ramps to reduce runoff or ponding in the ADA pathway.
- E. All private roads shall collect onsite surface runoff prior to flowing across any public walkways and convey the runoff to the public drainage system without impacting the pedestrian travel way.

7.06 Intersection Grades

- A. On sloping approaches at an intersection, landings shall be provided with grade not to exceed one foot difference in elevation for a distance of 30 feet approaching an arterial or 20 feet approaching all other streets, measured from the edge of traveled way.

7.07 Pedestrian Treatments

- A. Accommodations for pedestrians shall be designed into all intersections. Pedestrian accommodations include sidewalks, crosswalks, pedestrian refuge islands, and pedestrian signals and signal buttons. All pedestrian accommodations must be designed to meet current ADA standards.

- B. Vaults, covers, castings, or drainage grates shall not be placed within the crosswalk, or within curb ramps or landing areas.
 - 1. Where it is infeasible to relocate utility structures or lids outside of the pedestrian pathway, they must be treated with a slip-resistant material in compliance with current ADA regulations and guidance.
- C. Crosswalks shall be provided on all new stop-controlled intersections where the highest roadway classification exceeds a local access street. Crosswalk may be required on local access streets at the discretion of the City Manager. Where required, crosswalk markings shall comply with KCRS Figure 4-002 and Figure 4-003
- D. Curb ramps shall be provided per Section 8.05
- E. When street paving or re-surfacing impacts the accessible route through the intersection, including crosswalks and legal crossing locations, the intersection must be retrofitted or upgraded to meet the current ADA standard; retrofits and upgrades may be required on all curb ramps, landings, pedestrian signals, and pedestrian push buttons associated with the impacted accessible route.

7.08 Sight Distance Triangle

- A. For the intersection of a driveway with a public street, a sight distance triangle for a site access point shall be determined by measuring 15 feet along the edge of travel way and 15 feet along the edges of the driveway beginning at the respective points of intersection. The third side of each triangle shall be a line connecting the end points of the first two sides of each triangle.
- B. Where pedestrian facilities, including walk able shoulders, exist at an intersection of a driveway with the public street, a sight distance triangle for a site access point shall be determined by measuring 15 feet along the back edge of the walkway and 15 feet along the edges of the driveway beginning at the respective points of intersection. The third side of each triangle shall be a line connecting the end points of the first two sides of each triangle.

7.09 Bicycle Accommodations

All intersection shall be designed to accommodate bicycle facilities to the maximum extent feasible.

- A. Bicycle lanes shall be clearly distinguished with striping and signage as needed to safely move vehicles and bikes through any given intersection allowing proper consideration for merging traffic and the addition of lanes, or lane transitions, required for turning movements through the intersection.
- B. Bicycle boxes shall be provided at all signalized intersections unless otherwise approved by the City Manager. Bicycle boxes, where required, shall be filled with green surface painting unless otherwise approved by the City Manager.

Section 8: Roadside Features

8.01 Sidewalks

- A. Sidewalk shall be constructed in the location and at the width identified in Section 6. Sidewalk width dimensions shall be exclusive of, and in addition to, any portion of the curb and gutter, pedestrian curbing, fencing, and/or fall protection measures.
- B. Sidewalk shall be constructed with Portland cement concrete surfacing.
 - 1. Permeable cement concrete pavement may be used where soil conditions are favorable, subject to approval by the City Manager.
- C. Sidewalks shall be constructed adjacent to the required amenity zone, between the amenity zone and the limits of right-of-way. Where an amenity zone is not provided or required, sidewalk shall be constructed next to the curb or parking strip unless otherwise approved by the City Manager.
- D. Extended off-street walkways may be required by the City Manager to provide direct connections to existing pedestrian facilities or along Safe Routes to School as identified by City or school district.
- E. Sidewalk adjacent to retaining walls above the sidewalk elevation shall be 1 foot wider than the minimum width listed in Section 6 unless otherwise approved by the City Manager.
- F. All utility lids within the sidewalk surface shall comply with current ADA vertical discontinuity standards and shall be coated with a slip resistant coating compliant with current ADA standards.
- G. No fixed object may be placed within the sidewalk, including utility poles and poles bases, which restrict the sidewalk width to less than 4 feet minimum.

8.02 Curb & Gutters

- A. Vertical curb and gutter shall be used on all new or widened public roads.
- B. Rolled curb is only permitted where it replaces or matches existing conditions, is used as part of a traffic calming device, or is used as part of an alternative roadway design. Except for cases which are solely replacement of existing curb, the use of rolled curb must be approved by the City Manager.
- C. Extruded curb is not allowed in public right-of-way, unless it is otherwise approved by the City Manager.

8.03 Construction of Curbs, Gutters, and Sidewalks

- A. Sub-grade compaction for curbs, gutters, and sidewalks shall meet a minimum 95 percent of maximum density. A minimum 4-inch section of crushed surfacing is required below the curb, gutter and sidewalk.
- B. Concrete for curbs, gutters, and sidewalks shall be Class 4000, furnished and placed in accordance with WSDOT/APWA Standard Specifications, Sections 6-02, 8-04, and 8-14. Cold and hot weather precautions as set forth in WSDOT/APWA Standard Specifications Sections 5-05.3(14) and 6-02.3(6)A shall apply.
- C. Sidewalks shall be constructed of concrete with a minimum 5-inch thickness.
- D. Sidewalk shall be constructed in compliance with current ADA standards.
- E. Concrete sidewalks shall be cured for at least 72 hours. Curing shall be by means of moist burlap or quilted blankets or other approved methods. During this curing period, all traffic, both pedestrian and vehicular, shall be excluded.
- F. Curb shall be constructed per KCRS Figure 3-002 and Section 9.02

- G. Joints shall be spaced at ten (10) foot intervals and in accordance with KCRS Figure 3-001.
- H. Transitions between curbs with sidewalks to shoulder roadway sections shall meet the following requirements unless otherwise approved by the City Manager:
 - 1. At intersections, curb wraps shall extend around the entire radius and curb ramp(s) shall be provided at the terminus corner.
 - 2. For straight connections or mid-block transitions, a temporary concrete ramp, compliant with ADA standards shall be provided.
 - i. KCRS Figure 3-014 may serve as a general guideline for construction of the ramp, but may be subject to revisions of the ADA requirements.
 - ii. An ADA compliant detectable warning surface is required at the bottom of the ramp.
 - iii. Where the bottom of the ramp lies outside the limits of existing pavement, a minimum 4 foot by 4 foot asphalt landing shall be provide which does not exceed 2% maximum slope in any direction and the entire distance between the landing and existing edge of pavement shall be paved.

8.04 Expansion Joints and Sidewalk Finishing

- A. An expansion joint consisting of 3/8 inch or 1/4 inch of pre-molded joint material shall be placed full depth around fire hydrants, poles, posts, and utility castings and along walls or structures in paved areas. Joint material shall conform to the requirements of ASTM D994 (AASHTO M33). See KCRS Figure 3-001.
- B. An expansion joint consisting of 3/8 inch or 1/4 inch of pre-molded joint material shall be placed in the upper two inches of curbs and sidewalks at 10-foot intervals and at sides of drainage inlets. When curbs and/or sidewalks are placed by slip forming, a pre-molded strip up of 1/2 inch thick expansion joint, with a 2 inch to full depth section as described above.
- C. Expansion joints in sidewalk shall be located so as to match the joints in the curb whether sidewalk is adjacent to curb or separated by planting strip.
- D. Interface between curb and adjacent sidewalk on integral pour construction shall be formed with 1- inch radius edging tool. On separate pour construction an expansion joint consisting of 3/8 inch or 1/4 inch of pre-molded joint material shall be placed full depth between the curb or thickened edge and the adjacent sidewalk.
- E. Unless otherwise specified in Section 2.06, sidewalk finishing shall be trowelled smooth with a steel trowel. Before jointing or edging, the surface of the walk shall be lightly brushed in a transverse direction (perpendicular to roadway) with a soft brush. Tool marks consisting of 1 inch V-grooves must be made in the sidewalk at five-foot intervals, intermediate to the expansion joints.

8.05 Curb Ramps

- A. On all curbed streets, ramped sections to facilitate passage of disabled persons shall be constructed through curb and sidewalk at street intersections, other crosswalk locations, or anywhere a raised pedestrian facility begins or terminates.
- B. In general, when a feature in the right-of-way is altered, the requirements for new construction must be applied to the maximum extent feasible within the scope or boundary of the project that has been planned.
- C. Overlays and most surface treatments which impact the crosswalk or pedestrian pathway between

existing curb ramps are considered alterations of the right-of-way and require upgrading ADA facilities to current standards.

- D. All proposed, altered, or constructed ramps shall meet all current ADA standards to the maximum extent feasible. Where all elements of the ADA requirements cannot be met, the project engineer shall provide Maximum Extent Feasible (MEF) documentation. MEF documentation must:
 - 1. Identify any portion of all ramps associated with the project which are not fully compliant, and
 - 2. Provide justification for why those elements cannot be designed or constructed to be fully compliant, and
 - 3. Include a stamp and signature from the licensed engineer responsible for the documentation, and
 - 4. Be approved by the City's Public Work Director prior to final construction approval or release of any performance agreements.
- E. The curb ramp details provided in Appendix B are intended as general guidance; errors or omissions in the detail drawing do not excuse the applicant from having to fully comply with the ADA standards. In the case that ADA standards are updated and the details no longer represent the current ADA standard or interpretations, the detail shall be considered void and shall not be referenced in plans or construction documents.
- F. Each proposed curb ramp shall be specifically detailed on the construction drawings with unique site elevations based on the proposed design and shall provide spot elevations at all significant grade breaks including, but not limited to, all corners of the required landings, the top and bottom of ramp, and gutter slope.
- G. Where a ramp is constructed on one side of the street and a sidewalk or raised pedestrian facility exists on the opposite side of the street, a receiving ramp shall also be provided on the opposite side of the street. Where a raised pedestrian facility does not exist on the opposite side, a second ramp is not required.
- H. Two ramps shall be provided per curb return, to the maximum extent feasible.
- I. Curb ramps shall be positioned so that a ramp opening is situated within the marked crosswalk, or crossing area if unmarked. See Section 7.07 for additional direction.
- J. The ramps shall have detectable warnings surfaces consisting of raised truncated domes and a contrasting surface across the entire opening of the ramp. The surface shall extend joint to joint across the opening and shall remain within 2-inch of the back of curb at all points.
- K. Directional ramps shall not be permitted unless used as temporary ramps at the end of frontage improvements which are located outside the limits of an intersection, or as otherwise approved by the City Manager.

8.06 Concrete Steps and Barrier-Free Access Ramps

- A. Steps shall only be used where an acceptable alternative access is available for barrier-free access, and there is a need for a separate stairway. Where used, concrete steps shall be approved by the City Manager and constructed in accordance with KCRS Figure 5-007 or other design acceptable to the City Manager and consistent with the WSDOT/APWA Standard Specifications.
- B. Ramps used to provide barrier-free access shall have a maximum slope of 12:1 with a maximum rise of 30 inches between landings. Landings shall be a minimum of 5-feet by 5-feet.
- C. Handrails, whether for steps or other applications, shall be provided consistent with KCRS Figure 5-007

and the WSDOT/APWA Standard Specifications.

8.07 Asphalt Shoulders

- A. Asphalt paved shoulders may only be used where approved by the City Manager on existing roads to provide for bicycle and pedestrian use.
- B. Where shoulders are provided, they shall be delineated by a four-inch white thermoplastic edge line; additional raised pavement markers for further delineation of the shoulder may be required for pedestrian safety at the discretion of the City Manager.

8.08 Bikeways

Every effort shall be made to include safe bikeways on all new roadways and reconstruction projects, unless bicyclists are prohibited by law from using the roadway. Design considerations for bikeways shall be assessed on a case by case basis, but shall generally comply with the following standards:

- A. At a minimum, projects shall include the bicycle facilities identified in the City Transportation Element of the Comprehensive Plan and as shown in Appendix A, unless otherwise approved by the City Manager
- B. The planning and design of bikeways in any category shall be in accordance with the WSDOT Design Manual and the AASHTO Guide for the Development of Bicycle Facilities, current edition.
- C. Bike lanes, where required, shall be a minimum of 5 feet in width unless otherwise approved by the City Manager.
- D. Pavement markings shall be used on bike lanes and paths according to MUTCD and AASHTO Guide for the Development of Bicycle Facilities, current edition.
- E. The design of all signalized intersections shall address bicycle usage.

8.09 Fixed Objects

In addition to sound engineering judgment and analysis, the following minimum standards shall apply to all new or relocated placements of fixed, or non-break-away, objects within the public right of way. Existing utilities which are not in compliance with these standards are not required to be relocated until such time that a repair, reconstruction, replacement, expansion, or relocation of the utility structure is planned. The following constraints on obstacle location will not apply to locations not accessible by moving vehicles, "breakaway" structures whose break-off resistance does not exceed that of a single 4 inches x 4 inches wood post or a 1.5-inch standard (hollow) iron pipe or to "breakaway" fire hydrants installed to manufacturer's specifications.

- A. Fixed objects along SR-522/Bothell Way NE, or any roadway with a posted speed limit exceed 35 mph, shall comply with the Clear Zone requirements of Chapter 1600 of the WSDOT Design Manual.
- B. On roadways less than 35 mph, no new fixed object shall be placed with any portion of the object being closer than 2' to the face of curb.
 - 1. The City may require that a clear zone analysis be submitted and approved by the City prior to a permit being issued for a project which proposes a fixed object placed within 10 feet of the travel way for boulevards, urban avenues, and/or neighborhood connections.
- C. Fixed objects within a public right of way shall not be located closer than ten feet to any driveway or private road, unless a modification is approved by the reviewing Engineer. Fixed objects shall be located such that they do not compromise vehicular or pedestrian sight distance.
- D. All clear zone measurements shall be taken from the edge of travel way. The edge of travel way shall be

defined as the interior limits of the fog line where edge striping exists or the edge of pavement or face of curb where edge striping does not exist.

8.10 Amenity Zone

- A. All streets constructed or improved under these Standards shall have an amenity zone per Appendix A, Section 6.04, or Section 6.05
- B. Amenity zones shall be no less than 4 feet in width unless otherwise approved by the City Manager.
- C. The amenity zone must be between the curb and the sidewalk, unless site conditions, or an approved alternate street design, preclude this location.
- D. Street light poles, traffic signs, and other public amenities should be located in the amenity zone to the maximum extent feasible.

8.11 Illumination

- A. Street signage and lighting is required for all new subdivision, commercial, or multifamily projects, unless otherwise approved by the City Manager, in accordance with Kenmore Municipal Code 17.20.105 and 17.20.107 respectively.
- B. All new street lights in the City of Kenmore shall be LED compatible and shall provide a new LED bulb at the time of installation.
- C. Street illumination shall be provided on all new roadways. Illumination will also be required as identifiers when a local road intersects an arterial. Illumination of roadways with turn channelization will include all lane tapers.
- D. The illumination system shall be designed to provide a minimum of 1.2 foot-candles with an average-to-minimum uniformity ration of 3:1, except at intersections where the system shall be designed to provide a minimum of 1.5 foot-candles with an average-to-minimum uniformity ratio of 3:1.
- E. When illumination is required for sag vertical curves the system shall be designed to provide a minimum of 0.4 foot-candles within the limits of the sag curve with a maximum average foot-candle value of 1.0. If an intersection is adjacent to the sag vertical curve, the illumination must include the intersection.
- F. A photometric analysis of the lighting pattern for a specific project may be substituted for these standards if approved by the City.
- G. Developers / applicants shall contact Puget Sound Energy's Into-Light Division for design services.
- H. Complete calculations for structural design, including anchor bolt details, shall be prepared by a Professional Engineer, licensed under Title 18 RCW, State of Washington, in the branch of Civil or Structural Engineering.
- I. In all areas of the City except for those areas which are zoned downtown residential, downtown commercial, community business, and regional business, urban corridor, and waterfront commercial zones the street lighting shall be installed using the following product types unless otherwise approved in writing by the City Manager:
 - 1. Base Style: Victorian V
 - 2. Base Material: Concrete
 - 3. Base Color: Black
 - 4. Head Type: Dayform
 - 5. Head Color: Black

8.12 Landscaping

- A. Street trees and landscaping should be incorporated into the design of road improvements for all classifications of roads.
- B. Street trees are required at 40 foot centers on all public local access roads and as directed per the road section in Appendix A for arterials, boulevards, and neighborhood connections.
- C. The trees shall be:
 - 1. Located within the amenity zones when required and within the street right-of-way when feasible and when approved by the City;
 - 2. A species approved by the City if located within the street right-of-way and compatible with overhead utility lines;
 - 3. Maintained by the adjacent landowner unless part of a City maintenance program; and
- D. The trees may be spaced at irregular intervals to accommodate sight distance requirements for driveways, intersections, utilities, and/or Low Impact Design facilities.
- E. All trees adjacent to walkways shall have a 7-foot minimum branching height at time of planting. This may be reduced if trees are more than 5 feet from the back of sidewalk.
- F. Minimum height clearance of existing trees adjacent to new road shall be 15 feet above the finished roadway grade.
- G. Commercial root barriers shall be required for all trees planted in amenity zones or at the back of sidewalks and curbs.
- H. Additional landscaping features may be required for downtown areas as identified in Section 2.06.

8.13 Mailboxes

- A. All projects which create new or additional residential, commercial, or industrial units must provide necessary improvements for mail delivery in accordance with the Bothell Post Master.
- B. Mailbox products and installation shall be in accordance with the Post Master requirements.
- C. A minimum 5 feet clearance must be maintained around all portions of any mailbox placed within a sidewalk, shoulder, or walkway.
- D. Where existing mailboxes will be impact by required street improvements, temporary considerations must be made in order to maintain constant mail services to all addresses.
- E. Where existing mailboxes will be impact by required street improvements, relocation or replacement of the existing mailboxes shall be coordinated with the Post Master and City inspector.
- F. Mailboxes for projects located within the downtown areas identified in Figure 2.1 shall coordinate mail delivery without placing a new mailbox along the project frontage; mail receptacles shall be placed on, within, or behind the building structure to the maximum extent feasible, subject to Post Master approval.

8.14 Cut and Fill Slopes

- A. Side slopes shall generally be constructed no steeper than 2:1 (H:V) on both fill slopes and cut slopes. Steeper slopes may be approved by the City upon showing that the steeper slopes, based on soil analyses, will be stable.
- B. Side slopes shall be stabilized by grass sod or seeding or by other planting or surfacing materials

acceptable to the City.

8.15 Guardrail

To ensure a safe roadway configuration, the following features shall be included in the roadway design in order of preference:

- A. 4:1 (H:V) or flatter fill slopes adjacent to the roadway where the slope drop is greater than 6 feet.
- B. Provide 3:1 (H:V) or flatter fill slopes where 4:1 (H:V) slopes cannot be provided and the slope drop is greater than 6 feet.
- C. Provide 2:1 (H:V) or flatter fill slopes where 3:1 or 4:1 (H:V) slopes cannot be provided and the slope drop is greater than 6 feet.
- D. Evaluate need for barrier systems and provide design in conformance with WSDOT/APWA Standard Plans, Standard Specifications, and the WSDOT Design Manual.

8.16 Vertical Drops

The standards of this section shall apply to new grading only and shall not require existing drops to be retrofitted unless additional grading work is proposed.

- A. All slopes which exceed 2:1 in slope shall be considered a vertical drop.
- B. Any vertical drop within, or immediately adjacent to, the right-of-way or other common area which exceeds 18 inches in total vertical height, as determined by the City, shall require a handrail or fence sufficient to address the fall hazard.
- C. Any vertical drop within, or immediately adjacent to, the right-of-way or other common area which does not exceed 18 inches in total vertical height, as determined by the City, shall require a minimum 4-inch pedestrian curb to separate the public improvements from the vertical drop.
- D. The City reserves the right to require handrail or fencing for any vertical drops within or adjacent to the right-of-way which are considered a safety hazard as determined by the city Manager.

Section 9: Surface Treatments

9.01 Residential Streets & Sidewalks

- A. The minimum pavement section for new residential streets, lanes, shoulders, sidewalks and bikeways shall be as indicated in Table 9-1.
- B. The minimum pavement thickness for repairs, patches, replacements, extensions, and/or modifications within existing residential streets, lanes, shoulders, sidewalks and bikeways shall match the existing pavement thickness or be as indicated in Table 9-1, whichever results in a greater thickness of pavement.
- C. Table 9-1 is only applicable for stable compacted subgrade constructed with suitable materials.
- D. Alternative, porous, or pervious pavement types may be used on private roadways and on public sidewalk only; use of alternative pavement within the right-of-way may require additional material submittals. Any alternative pavements shall be designed by a license geotechnical or civil engineer and appropriately designed for the proposed materials and site conditions and shall be approved by the City prior to construction.
- E. Any proposed exception to these materials may be subject to soils strength testing and traffic loading analysis, and subject to City review and approval. At any time during construction, should a question on the suitability or placement of native soil or import materials exist, the inspector may require a geotechnical evaluation to address soil conditions. When required, the report shall be prepared, stamped, and signed by a licensed geotechnical or civil engineer, registered in the State of Washington, and shall include an assessment of the site conditions and recommendations for corrective actions. A copy of maximum density curves and all associated compaction test reports shall be included with the report. All materials shall meet the requirements of the WSDOT Standard Specifications unless otherwise approved.

Table 9-1 Residential Streets, Shoulders, Sidewalks, Walkways and Bikeways

TYPE OF FACILITIES	HOT MIX ASPHALT (HMA) CLASS ½-inch	HMA CLASS ¾-inch OR 1-inch	CRUSHED SURF. TOP COURSE	CRUSHED SURF. BASE COURSE	PORTLAND CEMENT CONCRETE
STREETS & SHOULDERS					
Preferred Design Section	2-inches	4-inches			
Optional Design Section	3-inches		1 ½-inches	8-inches	
Alternative Pervious Pavement (Private Only)	Per Engineer Design				
SIDEWALKS					
Standard Pavement				2-inches	4-inches Class 4000
Alternative Pervious Pavement	Per Engineer Design				

9.02 Requirements for Residential Streets on Poor Subgrade

The minimum material thickness indicated in Table 9-1 is not acceptable if there is any evidence of instability in the subgrade. This includes but is not limited to free water, swamp conditions, fine-grained or organic soil, slides or uneven settlement. If any of these characteristics are present, the soil shall be sampled, tested, and a pavement section designed in accordance with Section 9.03. Both the soils test report and the resulting pavement design will be subject to review and approval by the City.

9.03 Arterials and Commercial Access Streets

- A. Rigid pavement designs for arterial and commercial access streets shall be prepared by a licensed professional civil engineer registered in the State of Washington and in accordance with the current “AASHTO Guide for Design of Pavement Structures”.
- B. Flexible pavements shall be designed using a layered design analysis in accordance with the “AASHTO Guide for Design of Pavement Structures”.
- C. Materials shall meet WSDOT specifications.
- D. The pavement design shall be based on soil parameters reflecting actual field or laboratory tests, and a traffic loading analysis. A subsurface investigation shall be performed in order to provide information on any materials that would cause settlement, stability, or drainage problems. Soil used for the design analysis shall be representative of the native subgrade conditions. The traffic loading analysis shall include traffic volume, percentage growth rate, and axle loadings.
- E. Pavement design sections shall not be less than those required for residential streets.
- F. The roadway section for a multi-family residential development can be designed and constructed to meet the requirements of a residential roadway section.
- G. The following design inputs shall be used for calculation of the pavement section:
 1. Pavement Design Life = 20 years
 2. Reliability (R) = 85%
 3. Overall Standard Deviation (S_0) = 0.50
 4. Design Serviceability Loss (ΔPSI) = 1.5
 5. Drainage Coefficient (m) ≤ 1.0
 6. Layer Coefficients
 - i. Hot Mix Asphalt: ≤ 0.44
 - ii. Crushed Surfacing: ≤ 0.14
 7. Resilient Modulus (M_r)
 - i. HMA: $M_r = 450,000$ psi
 - ii. Crushed Surfacing Materials: $M_r = 28,000$ psi
 - iii. Subgrade Soil: The subgrade M_r is based on actual field or laboratory tests. The subgrade M_r value used in the pavement design is not to exceed 15,000 psi.
- H. Resilient modulus values for the subgrade soil shall be determined by Laboratory M_r tests or Falling Weight Deflectometer tests (FWD) performed in situ or default M_r values based on soil classification per the Unified Soil Classification System (USCS). The soil classification shall be based on laboratory testing of representative samples of subgrade soil.
- I. USCS soil types shall be determined per ASTM D 2487. Default M_r values based on the USCS are as

follows:

Class	M _r (psi)	USCS Soil Type
A	15,000	GW, GP, GW-GM, GP-GM
B	12,500	GM, SW, SP
C	10,000	SW-SM, SP-SM, SM-ML ¹
D	7,500	GW-GC, GP-GC, SW-SC, SP-SC, SM-ML ²
E	2,500	GC, GC-GM, SC, SC-SM, CL, CL-ML
F	Special Design ³	MH, CH, OL, OH, Peat

⁽¹⁾ Nonplastic

⁽²⁾ Plastic

⁽³⁾ Class F soils require a special design required to stabilize the subgrade and will be subject to review and approval by the City.

9.04 Street Widening

- A. When an existing asphalt paved street is to be widened the following requirements shall apply unless otherwise approved by the City Manager.
1. The edge of the driving lane shall be sawcut to provide a clean, vertical edge for joining to the new asphalt.
 2. The existing asphalt may require grinding and/or removal as directed by the inspector, depending on the condition of the surface and as needed to control surface water flow.
 3. After placement of the new asphalt section, the street shall be overlaid with a minimum of 2-inch HMA, Class 1/2-inch, plus a prelevel course, half-width throughout the widened area.
 4. All failures and cracking on road surfaces must be repaired prior to the overlay; the limits of the overlay will be based on the condition of existing pavement and the extent of required changes to the surfacing and channelization.
 5. If, for any reason, an overlay is not required, the joint shall be sealed with appropriate asphalt sealer.
 6. When the City determines that potential impacts from a development warrant subgrade repairs prior to the overlay, the applicant must provide a geotechnical report that includes recommendations for repairing the subgrade.
- B. If an existing shoulder, private driveway, or private roadway is proposed to be incorporated into a future traveled way the existing pavement shall be removed and replaced with a pavement section complying with these Standards. The responsibility for any shoulder material thickness improvement shall be considered part of the requirement for roadway widening.
1. Alternatively, a pavement evaluation can be performed. This evaluation shall analyze the structural capacity and determine any need for improvement. Designs based on these evaluations are subject to review and approval by the City.
- C. Any widening of an existing roadway, either to add traveled way, or paved shoulder, shall have the same surfacing material as the existing roadway.

9.05 Overlays

- A. Overlays shall require minimum thickness of 2-inches of new asphalt material.
- B. Where overlays are required, a 2-inch grind is required prior to the overlay to maintain finished surface elevations to the maximum extent feasible. Additional grinding may be required to meet drainage and ADA requirements. Overlays without grinding require approval from the City Manager prior to being approved.
- C. Existing asphalt berming or other drainage features to control surface runoff shall be maintained or restored during the overlay unless otherwise approved by the City Manager.
- D. Unless otherwise directed in writing by the City Manager, the existing crown or directional cross slope of a roadway shall be maintained after the overlay.
- E. Immediately following an overlay, the existing striping shall be restored as directed by the City inspector. Where striping cannot be permanently restored in the same day as the overlay, temporary striping shall be provided by the applicant to ensure safe movement of vehicles as directed by the City inspector. At the City's direction, existing striping may be revised to match cross sections proposed in Appendix A or in the City's Comprehensive Plan
- F. Where overlays match existing shoulders, transitions of material similar to the adjacent surface material shall be provided to ensure safe pedestrian use and acceptable vehicle transitions.

9.06 Materials and Lay-Down Procedures:

- F. Materials and lay-down procedures shall be in accordance with WSDOT/APWA Standard Specifications and the requirement of this section.
- G. Prior to placement of any curb, gutter, sidewalk, or pavement section a representative working under the authority of a licensed geotechnical engineer shall perform a compaction test on the sub-grade material; the material shall be compacted to a minimum of 95% of the maximum dry density before any paving material is placed.
 - 1. Compaction reports shall be submitted to the inspector prior to approval of any paved area.
 - 2. 1 compaction test shall be provided for every 100 linear feet of roadway, curb and gutter, or sidewalk. For roadway paving, the compaction requirement shall be assessed per travel lane.
 - 3. Separate compaction tests are required for each type of paved improvement (ie. curb and gutter vs. sidewalk vs asphalt roadway)
- H. An additional proof roll and field investigation may be requested by the inspector to confirm the sub-grade is firm and unyielding. A single or dual axle dump truck, loaded to a minimum 90 percent maximum gross weight capacity, shall be used to perform the proof roll.
- I. During surfacing activities utility covers in roadway shall be adjusted to the new finished grade.
- J. Asphalt shall not be applied to wet material. Asphalt shall not be applied during rainfall or before any imminent storms that might damage the construction. The City will have the discretion as to whether the surface and materials are dry enough to proceed with construction.

9.07 Asphalt Surfacing Repairs:

- A. When repairing shallow holes and gouges in asphalt less than 1-inch deep, the surface must be thoroughly cleaned and all loose or broken material must be removed from the hole. The bottom and edges of the hole/gouge shall be swabbed with asphalt tack. HMA shall then be placed into the hole or

gouge and thoroughly tamped or rolled. The edges shall then be sealed in accordance with Section 5-04.3(19) of the WSDOT/APWA Standard Specifications.

- B. For failures or holes/gouges exceeding 1-inch in depth, the minimum repair area shall be three feet beyond the perimeter. The existing pavement shall be sawcut or removed by a pavement grinder to the depth of the surrounding hole or damage. Asphalt for tack coat shall be applied to all surfaces of existing pavement in the repair area.
- C. HMA shall be placed in lifts of not greater than 0.35- foot compacted depth and shall be thoroughly and uniformly compacted to not less than 91 percent of the maximum density as determined by AASHTO Test Method T-209.
- D. Edges shall be sealed in accordance with Section 5-04.3(19) of the WSDOT/APWA Standard Specifications.

9.08 Pavement Markings, Markers, and Pavement Tapers

- A. Pavement markings and raised pavement markers shall be used to delineate channelization, transit lanes, bus zones, lane endings, crosswalks and longitudinal lines to control or guide all users of the roadway system and shall conform to KCRS Figures 4-001 through 4-009.
- B. When removal of existing pavement markings is required, a full-width overlay must be performed to remove any reflections of the old markings, unless otherwise approved by the City Manager.
- C. Channelization and transitions shall be required when through traffic is diverted around a lane or obstacle, when connecting full-width streets with different cross sections, and when extending an existing street with a new cross section different than the existing one. Channelization shall also be required to redirect traffic back to its original alignment.
- D. Channelization plans and crosswalk locations shall be approved by the City Manager.
- E. **Tapers:** Where pavement widening less than 300 feet in length is abruptly ended and edge lines do not direct traffic to through lanes, Type 2 raise pavement markers shall be installed at 10-foot centers near the end of the paved area at a 10:1 taper.
- F. **Crosswalks:** Crosswalks shall be installed at all intersections controlled by traffic signals and other areas approved by the City Manager. Crosswalks shall be installed in accordance with Section 7.07.
- G. All pavement markings shall be laid out with spray paint and approved by the City inspector before they are installed.
- H. Pavement markings for channelization shall be reflectorized hot or cold applied plastic. Extruded or sprayed markings shall be dressed with glass beads for initial reflectance. All materials shall have beads throughout to maintain reflectance as the material wears.
- I. Pavement markings that indicate fire apparatus zones shall comply with KMC.15.10.055.

Section 10: Drainage

10.01 General

- A. Drainage facilities shall be designed consistent with Kenmore Municipal Code 13.35 and the King County Surface Water Design Manual (KCSWDM), current edition, including pipe and ditch sizing, outfall protection, and temporary erosion and sediment control standards.
- B. No drainage from new downspouts, splash blocks, etc. shall discharge across a sidewalk, walkway, or roadway.
- C. Structures shall be placed and constructed as shown in the KCRS Figure 7-001 through Figure 7-029.
- D. Materials, construction, and testing are specified in the WSDOT/APWA Standard Specifications. The City Manager may amend, delete, or add specifications or Standard Drawings. The City Manager may request that additional details, specifications, or standards be developed by project engineers and/or contractors as needed for specific projects; such items may be used freely by the City and incorporated into future revisions of the Kenmore Street Standards.
- E. Where technical conflicts may occur between this document and the Surface Water Design Manual, the City Manager shall decide which document governs.

10.02 Road Ditches

- A. Filling or elimination of roadside ditches shall only be permitted for direct driveway access and construction of urban type frontage improvements (curb, gutter, sidewalk, etc) which include a public walkway, unless otherwise approved by the City Manager.
- B. Filling of existing ditches for any other reason, including for additional on-street parking, is not permitted unless otherwise approved by the City Manager. Furthermore, the City may request corrective action for any such filling activity which occurs without an approved permit from the City of Kenmore.

10.03 Storm Sewers and Culverts

- A. Minimum pipe size within the public right-of-way or on any system to be maintained by the City of Kenmore shall be 12-inch diameter unless otherwise approved by the City Manager.
- B. The minimum slope on all pipe types and sizes is 0.5% (V/H).
- C. Pipes shall be installed in accordance with Section 7-08 of the WSDOT/APWA Standard Specifications.
- D. Pipe systems and material type shall be designed in conformance with KCSWDM 4.2.1.
- E. All storm sewer pipe and culverts shall be covered by a minimum two feet of cover unless the applicant submits detailed plans accompanied by manufacturer's recommendations specifying allowable cover less than two feet in depth.
 - 1. Where 2 feet of covered cannot be provided, ductile iron pipe must be used and must maintain 1 foot of minimum cover.
- F. Pipes which convey runoff over, across, through, or down a steep slope as defined by KMC, must be surface mounted pipe which is fused or mechanically restrained at the joint and which is anchored per the requirements of KCSWDM 4.2.1.
- G. All culverts which collect surface runoff from landscaped areas, ditches, or interceptor trenches without

the use of a catch basin or manhole, shall include a debris cage or trash rack.

- H. All new connections to an existing public underground drainage system shall be at a new or existing catch basin or manhole; no mid-span connections, tees, or “core-tapping” are permitted.

10.04 Catch Basin Locations and Junctions

- A. Catch basins shall be spaced no greater than 150 feet for grades less than one percent, 200 feet for grades between 1 percent and 3 percent and 300 feet for grades 3 percent and greater.
- B. Catch basins, per KCRS Figures 7-003 through 7-006, rather than inlets shall be used to collect storm water from road surfaces, unless approved by the City Manager.
- C. Type 2 catch basins, per KCRS figure 7-005, shall be required where the depth to the invert of the pipe exceeds 5 feet, unless otherwise approved by City Manager.
- D. All type 2 catch basins require access ladders and/or handholds to within 18 inches of the top and bottom of the structure.
- E. Manholes, per KCRS Figures 7-007 through 7-011, may be used in lieu of catch basins if they do not collect surface water. Manholes must be used if inverts are greater than 18 ft deep, per KCRS Figure 7-005.
- F. Roof and yard drains, or other concentrated flow from adjacent property shall not discharge over the surface of roadways, sidewalks, walkways, or shoulders.
- G. Catch basins or manholes are required when joining differing types or sizes of pipes, unless otherwise approved by the City Manager.

10.05 Frames, Grates, and Covers

- A. Metal castings for drainage structures shall not be dipped, painted, welded, plugged or repaired.
- B. Porosity in metal castings for drainage structures shall be considered a workmanship defect subject to rejection by the City.
- C. Castings for manhole rings shall be gray-iron conforming to the requirements of AASHTO M 105, Grade 30B. Covers shall be ductile iron conforming to ASTM A 536, Grade 80-55-06. Manhole rings and covers shall support a minimum loading of 25,000 pounds. All mating surfaces shall be machine finished to ensure a non-rocking fit.
- D. All manhole rings and covers shall be identified as specified in the WSDOT/APWA Standard Specifications, Section 9-05.15.
- E. Castings for metal frames for catch basins and inlets shall be cast steel, gray iron, or ductile iron as specified in Sections 9-06.8, 9-06.9, or 9-06.14 of the WSDOT/APWA Standard Specifications.
- F. Castings for metal frames for catch basins, inlets, grates and solid metal covers shall support a minimum loading of 25,000 pounds.
- G. Castings for grates and solid metal covers for catch basins and inlets shall be cast steel or ductile iron as specified in Sections 9-06.8 or 9-06.14 of the WSDOT/APWA Standard Specifications. The foundry name and material designation shall be embossed on the top of the grate. The material shall be identified as “CS” for cast steel and “DUC” or “DI” for ductile iron and shall be located near the manufacturer’s name.
- H. All grates and covers, including large grates placed over detention or water quality vaults, shall be seated properly to prevent rocking, including the replacement of existing covers with solid metal covers. Any warping or curvature of the metal that is not specified in the details or specifications shall be considered a workmanship defect subject to rejection by the City.

- I. Subject to prior approval by the City Manager, other types and materials and drainage hardware may be used provided that recognized specifications are available to control quality and acceptable user experience with the product can be shown.
- J. Unless otherwise specified, vaned grates, per KCRS Figure 7-018, shall be used with standard frame in the traveled way, gutter, or shoulder. Vaned grates shall not be located within crosswalks.
- K. At sag vertical curves, on the end of downgrade cul-de-sacs, or before intersections with a grade four percent or greater, an analysis shall be done to assure that typical catch basin grates will collect the surface runoff. To collect excessive volumes of runoff or protect against plugged grates and overflow situations, the City Manager will require the use of through-curb inlet frames on vertical curbs, KCRS Figure 7-017. Where the through-curb inlets cannot be used, place a catch basin at the low point and two extra inlets located not greater than 0.1 foot above the low point grate within a distance of 25 feet.
- L. For new storm drains on existing rolled curb roadways use KCRS Figures 7-019 through 7-021.
- M. New catch basins that do not collect runoff shall use solid locking covers. See KCRS Figure 7-022. Existing catch basins, which no longer collect runoff, shall have their frame and grates replaced with solid covers, per KCRS Figure 7-015.
- N. All storm drain covers and grates within the City right-of-way shall require locking lids and bolts. Additionally, all control structure and/or detention system storm drain covers shall be locking regardless of their location including hinged access points and large open grates.
- O. Trench drains may only be used outside of City right-of-way unless otherwise approved by the City Manager. At a minimum, trench drains shall have catch basins or yard drains at either end unless used as a driveway culvert. The maximum distance between catch basins or yard drains along a trench drain shall be 100 feet.

10.06 Erosion Control

- A. Provide erosion control as required in the King County Surface Water Design Manual or as specified by other guidelines and/or regulatory requirements.
- B. When using geotextile for temporary silt fences, the material shall be designed specifically for erosion control. It shall meet the requirements of WSDOT Standard Specifications, Section 9-33.1, Table 6.
- C. Fencing must be inspected regularly and after each significant storm event for damage. Silt fencing does break down under UV light. Sediment collected behind the fence must be removed so that this material does not push the fence over.
- D. All sites shall be permanently stabilized prior to final approval.

10.07 Underground Structures

Where concrete structures are proposed below an area subject to traffic loading, including public roadways, private roadways, and parking lots, additional design consideration shall be applied.

- A. Large grates which do not utilize typical manhole or catch basin lids, but be located outside of the travel way, sidewalk, and any other public walkways.
- B. On private residential roads, residential access roads, and commercial access roads, maintenance access points and access openings shall be located to allow maintenance work to be completed while maintaining at least one lane open to vehicle travel.
- C. On arterials or any roadway identified on the City's Layered Network included in appendix 'A', residential access roads, and commercial access roads, maintenance access points and access openings shall be located to allow maintenance work to be completed while maintaining at least one lane in each

direction open to vehicle travel.

- D. Structures or vaults subject to traffic loading shall be structurally designed by a structural engineer currently licensed in the state of Washington to support HS-25 loading standards and shall include a design for an additional 45,000 lbs. point load, applied on an 18"x18" area.
 - 1. Structural design plans shall be submitted to and approved by the City prior to construction of any such structure.
 - 2. Additional striping or signage may be required at the discretion of the Fire Marshall to identify the structure location and alert emergency services of the structure below the surface.

Section 11: Utilities

11.01 Franchising Policy and Permit Procedure

- A. Utilities to be located within existing and proposed City right-of-way shall be constructed in accordance with current franchise and/or permit procedure and KMC 12.55, and in compliance with these Standards. In their use of the right-of-way, utilities will be given consideration in concert with the traffic-carrying requirements of the road which are, namely, to provide safe, efficient and convenient passage for motor vehicles, pedestrians, and other transportation uses. Aesthetics shall be a consideration.
- B. Underground installation of electric and telecommunication utilities is required in new urban development.
- C. All permits for new placement and replacement of existing utility poles and other utility structures above grade shall be accompanied by written certification from the utility's professional engineer or from an agent authorized by the utility to certify that the installations conform to these Standards and that the proposed work is in conformity with sound engineering principles relating to street safety and Section 8.09.
- D. Utilities are subject to Kenmore Municipal Codes and policies relating to drainage, erosion/sedimentation control and sensitive areas as set forth in Kenmore Municipal Code 13.35 and the Surface Water Design Manual.
- E. Requests for exceptions to these Standards will be processed in accordance with variance procedure as referenced in Section 1.03.

11.02 Standard Utility Locations within the Right-of-Way

- A. Utilities within the right-of-way on new roads or on roads where existing topography, utilities or storm drains are not in conflict shall be located as shown in typical sections, KCRS Figures 2-001 through 2-005, and as indicated below. Where existing utilities or storm drains are in place, new utilities shall conform to these Standards as nearly as practicable and yet be compatible with the existing installations. Above ground utilities located within intersections shall be placed so as to avoid conflict with placement of curb ramps and sidewalks. Mains and service connections to all lots shall be completed prior to placing of surface materials.
- B. Gas and Water Lines:
 - 1. Shoulder-and-Ditch Section: In shoulder 3 feet from edge of traveled lane.
 - 2. Curb and Gutter Section: 1.5 feet back of curb, or at distance which will clear root masses of street trees if these are present or anticipated. If back of curb is not feasible then in the street as close to the curb as practical without encroachment of the storm drainage system.
 - 3. Designated Side of Centerline: GAS: South and West. WATER: North and East.
 - 4. Depth: 36 inches (3 feet) minimum cover from finished grade, ditch bottom or natural ground.
- C. Individual water service lines and side sewers shall:
 - 1. Be placed with minimum 36-inch (3 feet) cover from finished grade, ditch bottom or natural ground.
 - 2. Use road right-of-way only as necessary to make side connections.
 - 3. For any one connection, not extend more than 60 feet along or through the right-of-way, or the

minimum width of the existing right-of-way.

4. Water meter boxes, when placed or replaced, shall be located on the right-of-way line immediately adjacent to the property being served, unless otherwise approved by the City Manager.
- D. Sanitary Sewers: In the general case, 5 feet south and west of centerline; depth 36-inch (3 feet) minimum cover from finished grade, ditch bottom or natural ground.
1. Side Sewers shall be provided to all adjacent lots or parcels.
 2. Side Sewers shall be placed within ten (10) degrees of perpendicular to road centerline.
- E. In the case of individual sanitary sewer service lines which are force mains the pipe shall:
1. Be minimum two inches I.D., or as required by the utility to maintain internal scouring velocity.
 2. If nonmetallic, contain wire or other acceptable proximity detection features; or be placed in a cast iron or other acceptable metal casing.
 3. Be placed with minimum three-foot cover from finished grade, ditch bottom or natural ground, within 10 degrees of perpendicular to road centerline, and extend to right-of-way line.
 4. Be jacked or bored under road unless otherwise approved by the City Manager.
- F. Sanitary and water lines shall be separated in accordance with good engineering practice such as the Criteria for Sewage Work Design, Washington Department of Ecology, latest edition.
- G. Gravity systems, whether sanitary or storm drainage, shall have precedence over other systems in planning and installation except where a non-gravity system has already been installed under previous approved permit and subject to applicable provisions of such permits or franchises.
- H. Electric utilities, power, telephone, cable TV, fiber optic conduit: All new services shall be installed underground with 36-inch (3 feet) minimum cover, either side of road, at plan location and depth compatible with other utilities and storm drains. If undergrounding of new utilities is not feasible at locations where ungrounded segments end or begin, new poles and other utility structures above grade shall conform to the following:
1. Utility poles or other approved essential roadside obstacles must comply with the clear-zone standards listed in Section 8.09.
 - a. Notwithstanding other provisions regarding pole locations described in these standards, no pole shall be located so that it poses a hazard to the general public. Utilities shall place and replace poles with primary consideration given to public safety. Existing utility poles that do not comply with City standards and are struck are considered to be a hazard by the City and shall be mitigated by the utility in accordance with these Standards. Additionally, existing utility poles that comply with City standards and are struck at least two times within the same ten-year period shall be mitigated by the responsible utility in accordance with these Standards.
 - b. Every effort shall be made to meet the standards during emergency replacement of existing utility poles and other structures. After a pole has been replaced, all utilities sharing that pole shall have a maximum of 180 days to relocate their facilities to the new pole and remove the old pole.
 2. Locations of poles shall also be compatible with driveways, intersections, and other road features (i.e., they shall not interfere with sight distances, road signing, traffic signals, culverts, etc.). To the extent possible, utilities shall share facilities so that a minimum number of poles are needed.
 3. Where road uses leave insufficient overhang, anchor, and tree-trimming space for overhead

utilities, additional easements and/or right-of-way may be required to accommodate the utilities. The costs associated with additional easements and/or right-of-way for this purpose shall be borne by the applicant, builder, or other party initiating the improvement. The associated cost of relocating the utility shall not be borne by the City.

11.03 Underground Installations

- A. All hard surface roadways shall be jacked or bored. Exceptions will be considered on a case-by-case basis as needed.
- B. Notwithstanding other provisions, underground systems shall be located at least 5-feet away from the road centerline. Additionally, the underground systems shall not disturb existing survey monumentation, unless there is no reasonable alternative.
- C. When approved, the open cut shall be a neat-line cut made by saw cutting a straight continuous line. The current WSDOT/APWA Standard Specifications, Sections 7-08 and particularly 7-08.3(3) will generally apply unless otherwise stated.
 - 1. Trench sides shall be kept as nearly vertical as possible.
 - 2. Compaction and restoration must be done as detailed below and immediately after the trench is backfilled, so as to cause least disruption to traffic. The asphalt or cement pavement shall be cut a minimum of one foot beyond all edges of the trench.
 - 3. After backfill and compaction an immediate cold mix patch shall be placed and maintained in a manner acceptable to the City.
 - 4. A permanent hot mix patch shall be placed and sealed with paving grade asphalt within 30 calendar days.
 - 5. Cement concrete pavement shall be restored in accordance with Section 5-05.3(22) of the WSDOT/APWA Standard Specifications.
 - 6. On crossings required to be opened to traffic prior to final trench restoration, steel plates shall be installed by the contractor with cold patch wedges on all sides or as directed by the City.
- D. Backfill in Roadway: The entire trench shall be backfilled with 5/8-inch minus crushed surfacing top course meeting the requirements of Section 9-03.9(3) of the WSDOT/APWA Standard Specifications unless otherwise approved by the City Manager.
 - 1. Native backfill may only be used upon approval of the material by the City inspector; the inspector may require a licensed geotechnical engineer to assess and certify the native material as suitable backfill.
 - 2. Backfill shall be placed and compacted mechanically in 6- inch lifts to 95 percent of the maximum density as determined by the compaction control tests described in Section 2-03.3(14)D of the WSDOT/APWA Standard Specifications. If the capability can be demonstrated, based on compaction equipment or quality of backfill to achieve 95 percent density in thicker lifts, the depth of backfill lifts may be increased up to 1 foot.
- E. Pavement Restoration: Restoration of a trench within an asphalt pavement shall include HMA to the same thickness as the existing asphalt pavement or per Section 9, whichever is the greater.
 - 1. Concrete pavement shall be restored consistent with Section 5-05 of the WSDOT/APWA Standard Specifications. Any concrete pavement traffic lane affected by the trenching shall have all affected panels fully replaced.
 - 2. Asphalt pavement shall be repaired depending on the impacts to the asphalt surface as directed

below:

- a. Any roadway surfaced within the previous 5 year shall be restored as directed in Section 2.07.
 - b. Cuts for pothole investigations, boring/receiving pits, for trenches which run perpendicular to the roadway which only impact one-side of the striped centerline, or for any cut which is entirely within limits of the roadway shoulder and is outside the existing or future travel way, shall neat cut the asphalt pavement 1 foot beyond the limits of the trench and patch with new asphalt material. The edges of the new asphalt patch shall be seal with asphalt binder (AR-4000 or approved equivalent).
 - c. Cuts running predominantly parallel to the roadway which only impact one side of the striped centerline shall be repaired as noted above in #2, except that the asphalt binder seal may be omitted and a half-width overlay must be provided between the striped centerline and the edge of pavement or curb and shall extend a minimum of 20 feet beyond the cut limits. Pavement undisturbed by trenching activities shall be ground as needed to meet the requirements of a half-width overlay.
 - d. Cuts of any type which impact more than one side of the striped centerline shall be repaired as noted above in #2, except that the asphalt binder seal may be omitted and a full-width overlay must be provided and shall extend a minimum of 20 feet beyond the cut limits. Pavement undisturbed by trenching activities shall be ground as needed to meet the requirements of a full-width overlay.
 - e. Any location where more than 2 separate cuts, of any type, are made within a 100 foot stretch of roadway shall be interpreted as a singular parallel cut with the overlay requirement as noted above.
 - f. Where a striped centerline does not exist, the half-width limits shall be at the crown line or as determined by the City Manager.
 - g. Overlays shall be consistent with Section 9.05.
- F. **Controlled Density Backfill:** As an alternative to mechanical compaction, trench backfill above the bedding and below asphalt concrete may be accomplished by use of controlled density backfill (CDF) in a design mixture according to Section 2-09.3(1) E of WSDOT/APWA Standard Specifications.
1. The contractor shall provide a mix design in writing and the CDF shall not be placed until the City has reviewed the mix design and authorized its use.
 2. CDF shall meet the requirements of Section 6-02 of the WSDOT/ APWA Standard Specifications and shall be accepted based on a Certificate of Compliance.
 3. The producer shall provide a Certificate of Compliance for each truckload of control density fill. The Certificate of Compliance shall verify that the delivered material is in compliance with the mix design.
- G. **Backfill outside the roadway prism:** Backfill outside the roadway prism shall be excavated material free of wood waste, debris, clods and/or any rocks exceeding six-inches in any dimension and meet compaction requirements.

11.04 Inspection & Notification

- A. The applicant shall adhere to inspection notification requirements as consistent with the approved permit, existing franchise agreement, and Section 4.

11.05 Final Adjustment (To Finish Grade)

- A. All utility covers, including drainage, which are located on proposed asphalt roadways, shall be temporarily placed at subgrade elevation prior to placing crushed surfacing material.
- B. Final adjustment of all covers and access entries shall be made following final paving by:
 - 1. Saw-cutting or neat-line jack hammering of the pavement around lids and covers. Opening should not be larger than 12 inches beyond the radius of the cover.
 - 2. Removing base material, surfacing course, and frame; adding risers; replacing frame and cover no higher than finished grade of pavement and no lower than one-half inch below the pavement.
 - 3. Filling and mechanically compacting around the structure and frame with crushed surfacing material or ATB, or placing in 5-inch minimum thickness of cement concrete Class 4000 to within 3 inches of the top.
 - 4. Filling the remaining 3 inches with HMA compacted and sealed to provide a dense, uniform surface.
 - 5. Final adjustment of all covers and access entries shall be completed within 30 days of final paving.

11.06 Final Cleanup, Restoration of Surface Drainage and Erosion/Sediment Control

In addition to restoration of the road as described above, the responsible applicant, utility, contractor, etc., shall care for adjacent areas in compliance with Sections 1-04.11 and 8-01 in the WSDOT/APWA Standard Specifications. In particular:

- A. Streets and roads shall be cleaned and swept both during and after the installation work.
- B. Disturbed soils shall be final graded, seeded and mulched after installation of utility. In limited areas seeding and mulching by hand, using approved methods, will be acceptable.
- C. Ditch lines with erodible soil and subject to rapid flows may require seeding, matting, netting, or rock lining to control erosion.
- D. Any silting or accumulation of construction debris of downstream drainage facilities, whether ditches or pipe and catch basins, which resulted from the construction activity shall be cleaned out and the work site restored to a stable condition as part of site cleanup.
- E. Remove all temporary erosion and sediment control materials and fencing and dispose of properly.

[END]

APPENDIX A



[TYPICAL ARTERIAL ROAD SECTIONS]

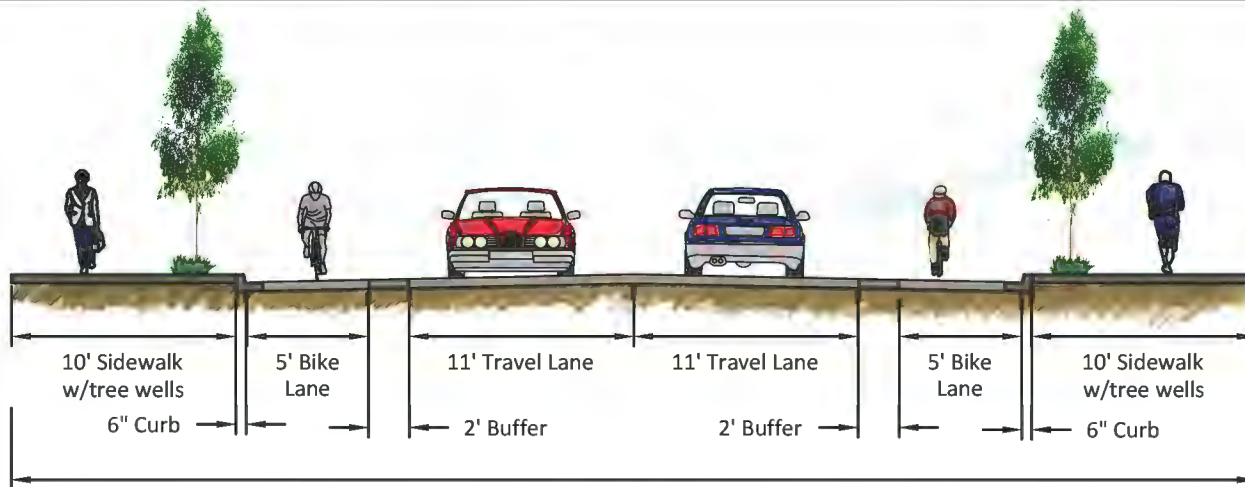

57' Developed
 Minimum 60' Right-of-way
 Exist 60' Right-of-way

68th Avenue NE
 (181st Street to 185th Street)
 Boulevard

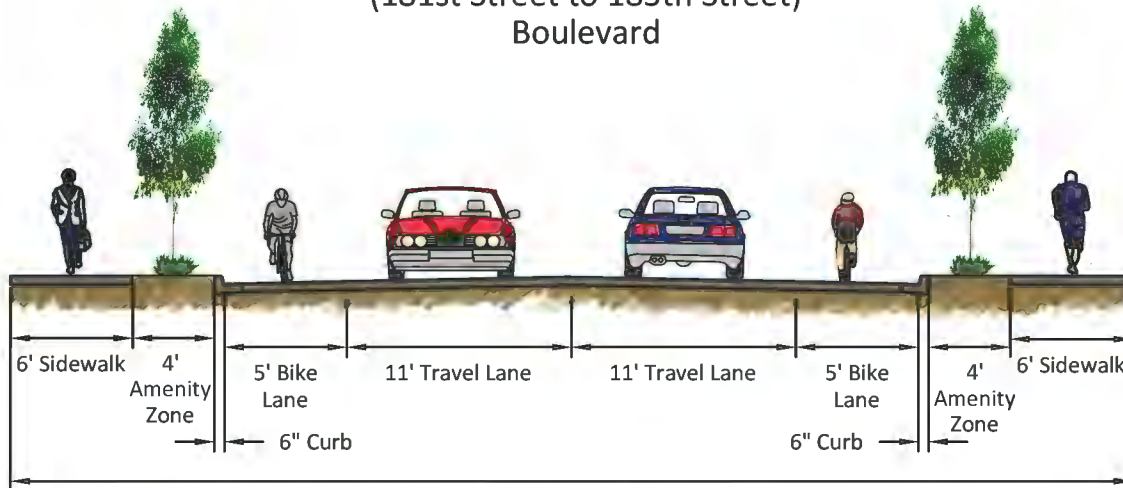

53' Developed
 Minimum 60' Right-of-way
 Existing 60' Right-of-Way

68th Avenue NE
 (185st Street to 202nd Street-Looking North)
 Neighborhood connection

NE 202nd Street
 (68th Avenue NE to 61st Avenue NE-Looking West)
 Neighborhood connection

Figure 1



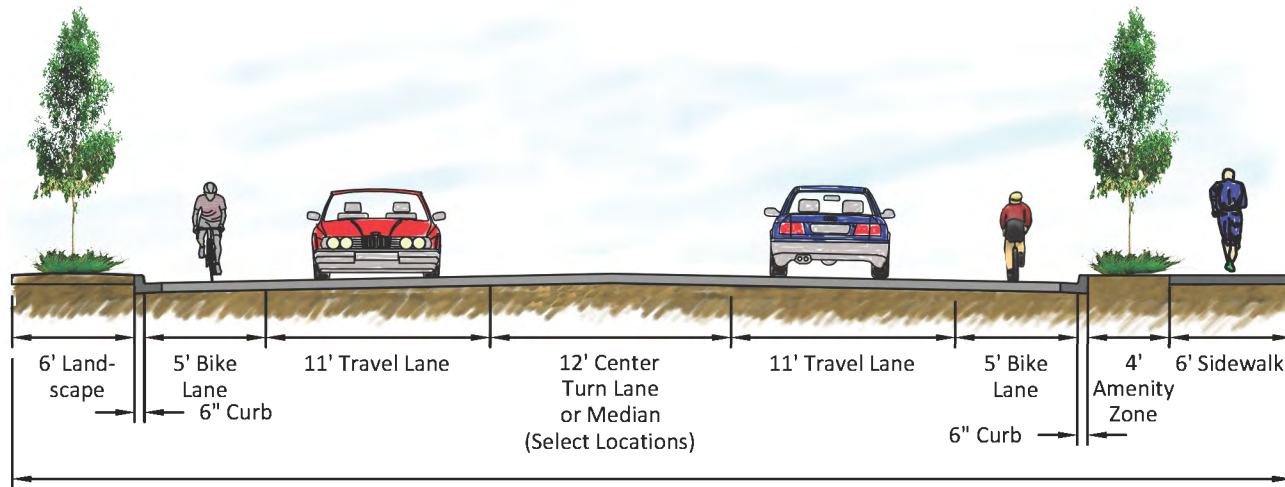

61' Developed
 Minimum 65' Right-of-way
 Existing 60' to 68' Right-of-way

61st Avenue NE
 (181st Street to 205th Street-Looking North)
 Boulevard

Figure 2

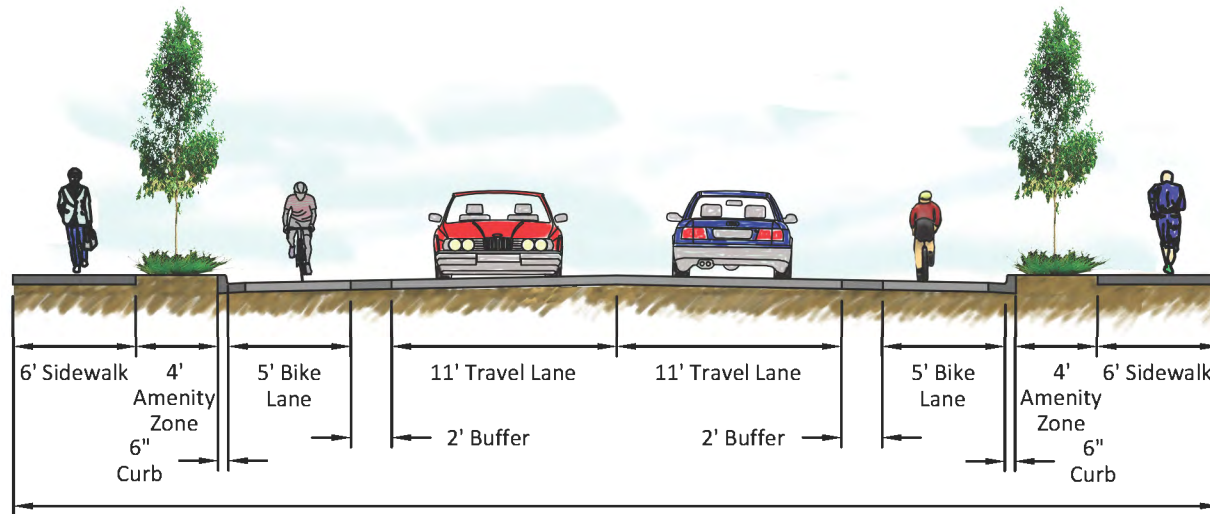

57' Developed
 Minimum 60' Right-of-way
 Existing 60' Right-of-way

80th Avenue NE
 (SR 522 to 205th Street)
 Boulevard

Figure 3



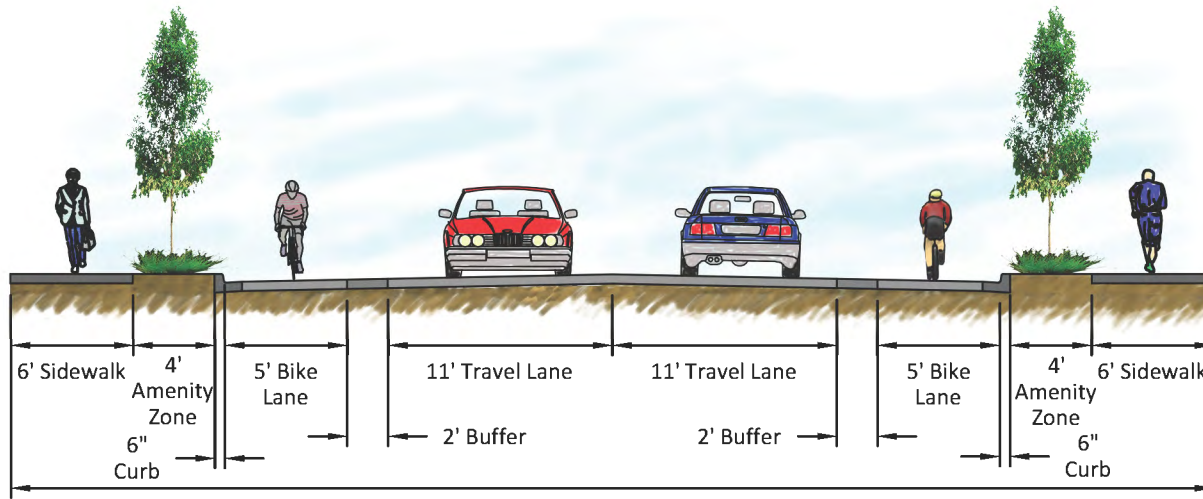

57' Developed
 Minimum 60' Right-of-way
 Existing 58' to 60' Right-of-way

73rd Avenue NE
 (181st Street to 205th Street)
 Neighborhood Connection

Figure 4



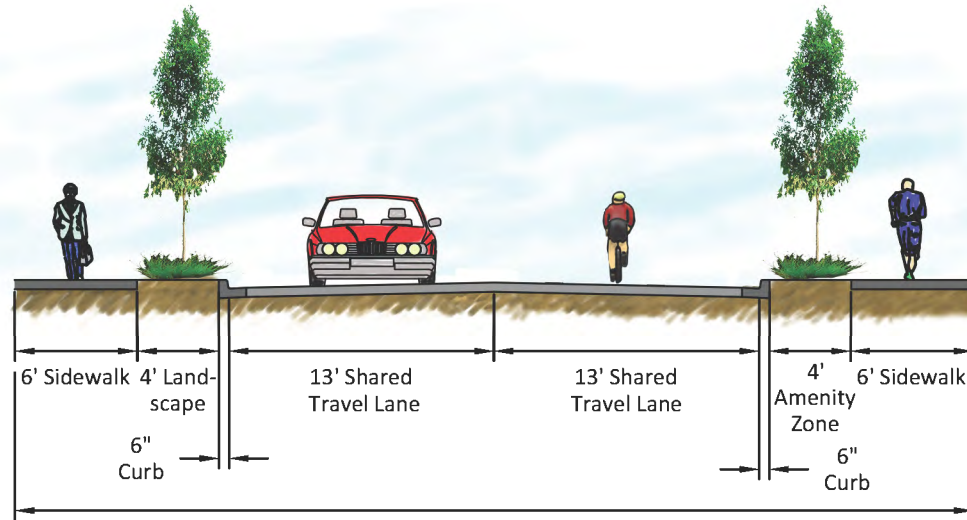

47' Developed
 Minimum 50' Right-of-way
 Existing 60' to 62' Right-of-way

NE 155th Street
 (Juanita Drive NE to Simonds Road-Looking East)
 Neighborhood Connection

*155th Street presently has sidewalks and a planter buffer on the north side of the street. planting buffers on the south side are a suggested developer option.

Figure 5



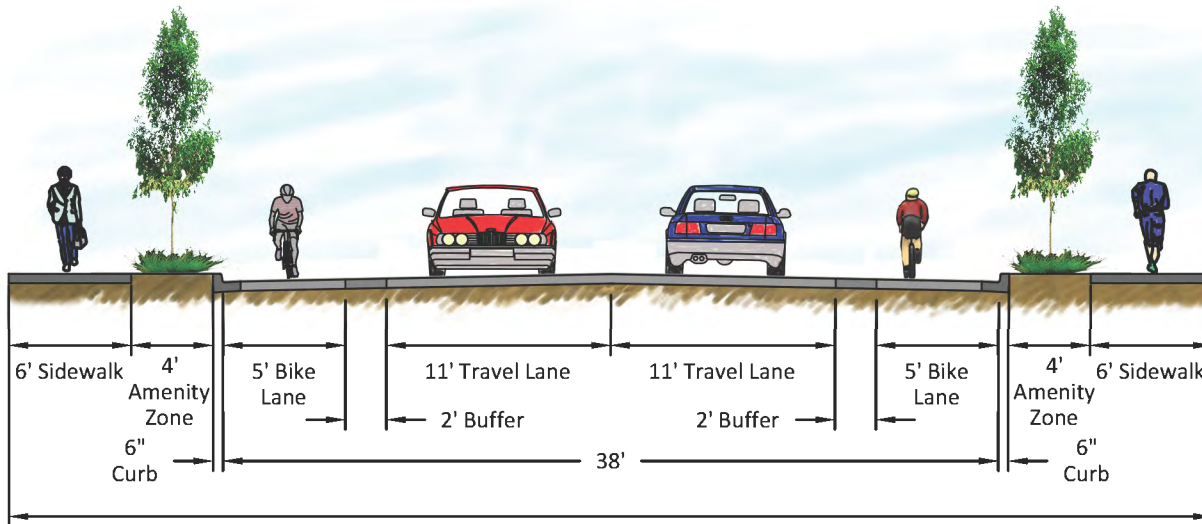

57' Developed
 Minimum 65' Right-of-way
 Existing 60' to 80' Right-of-way
 Existing Roadway Width: 36'±

Simonds Road - Restriping
 (NE 169th Street to 92nd Avenue NE)
 Boulevard
 NE 170th Street
 (Juanita Drive NE to NE 169th Street)
 Boulevard

*Overall roadway width, curb to curb, may vary. Minimum bike lane width shall be 5' and minimum travel lane width shall be 10'. 2' bike buffer will be maintained.

Figure 6



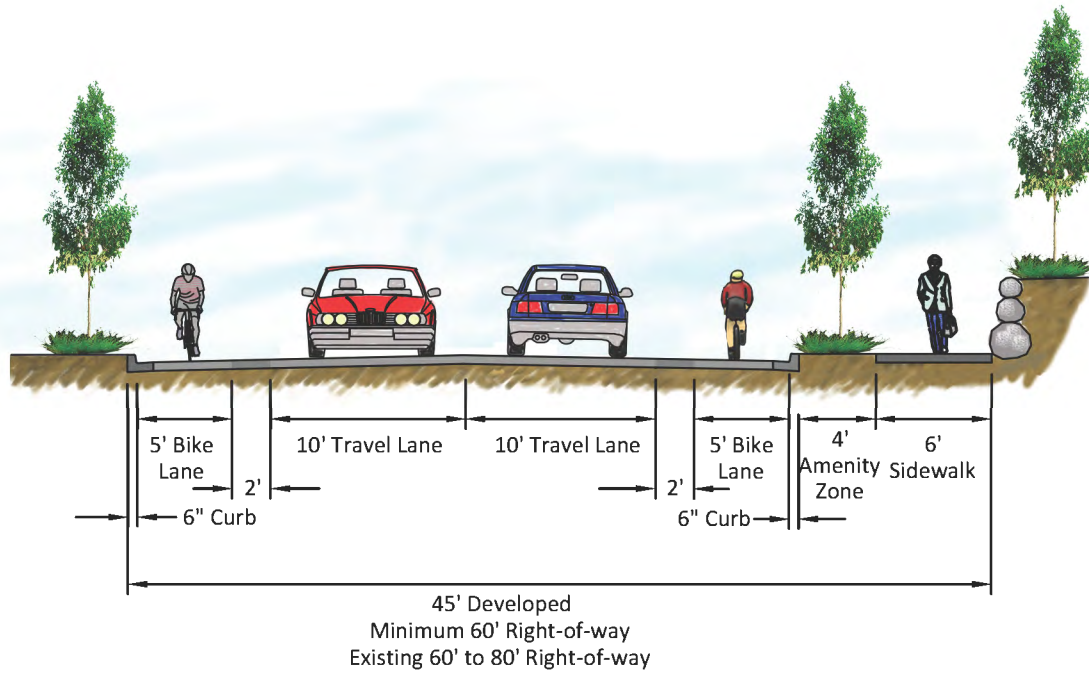

Juanita Drive NE
(Ne 170th Street to NE 141st Street-Looking North)
Boulevard

Figure 7



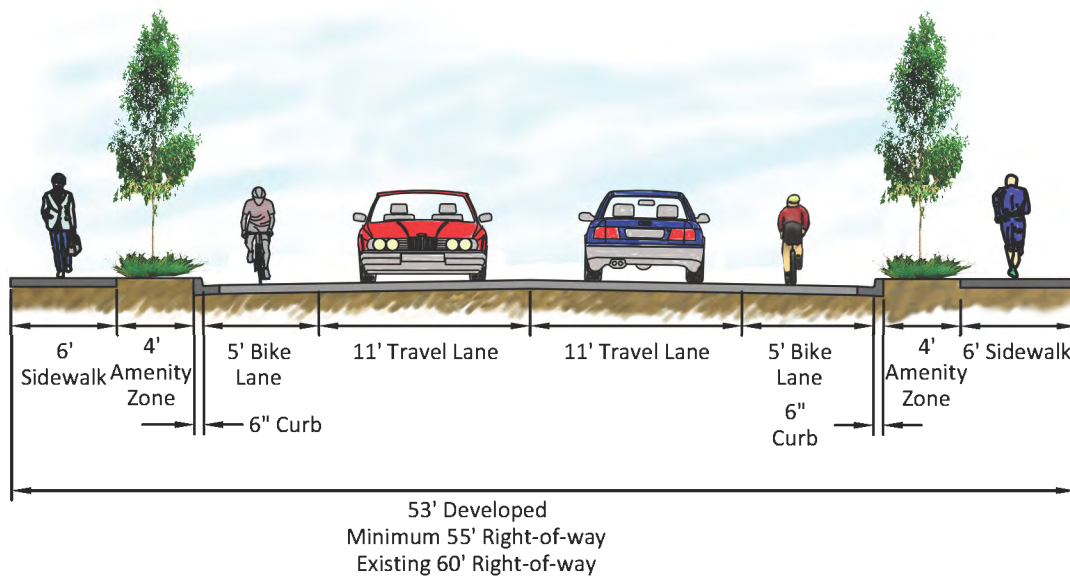

NE 192nd Street
 (73rd Avenue NE to 80th Avenue NE-Looking East)
 Neighborhood Connection

Figure 8



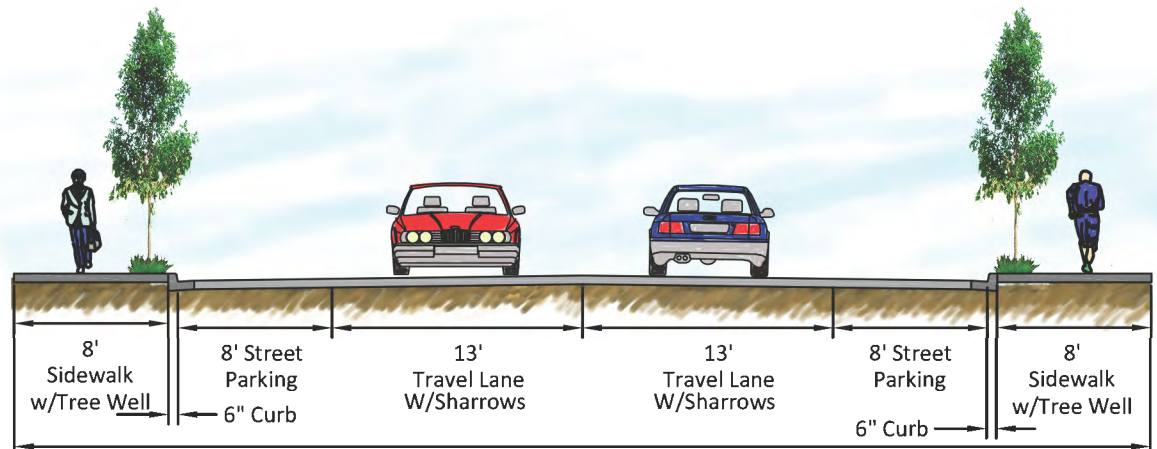

59' Developed
 Minimum 60' Right-of-way
 Existing 60' Right-of-way

NE 181st Street
 (65th Avenue NE to 73rd Avenue NE)
 Urban Avenue

Note: When traffic warrants 5' bike lanes
 and a 12" turn lane can be channelization (5', 10', 12', 10', 5')

Figure 9



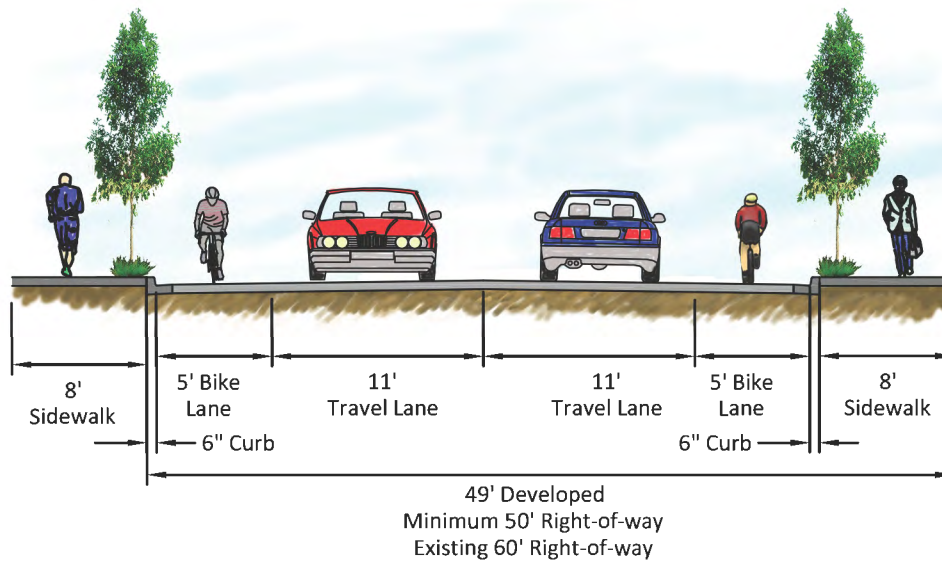

NE 181st Street
(61st Avenue NE to 65th Avenue NE-Looking East)
Neighborhood Connection

Figure 10



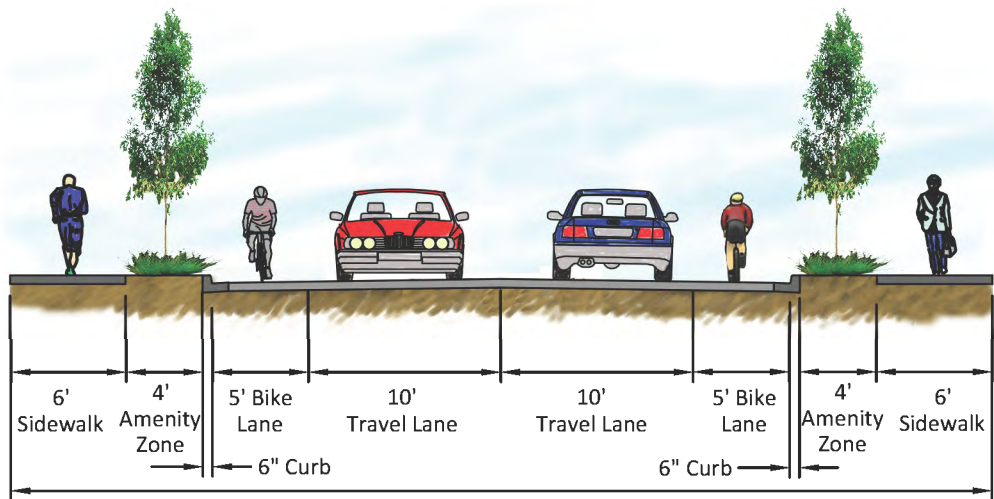

51' Developed
 Minimum 55' Right-of-way
 Existing 60' to 62' Right-of-way

84th Avenue NE
 (NE 145th Street & Simonds Rd NE)
 Neighborhood Connection

Figure 11



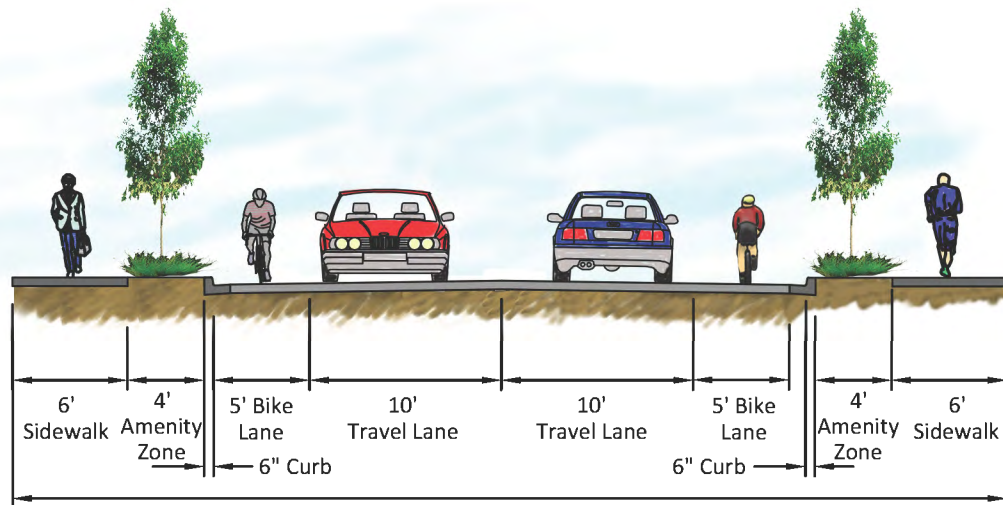

51' Developed
 Minimum 55' Right-of-way
 Existing 60' Right-of-way

NE 193rd Street
 (61st Ave NE to 55th Avenue NE-Looking West)
 Neighborhood Connection

Figure 12



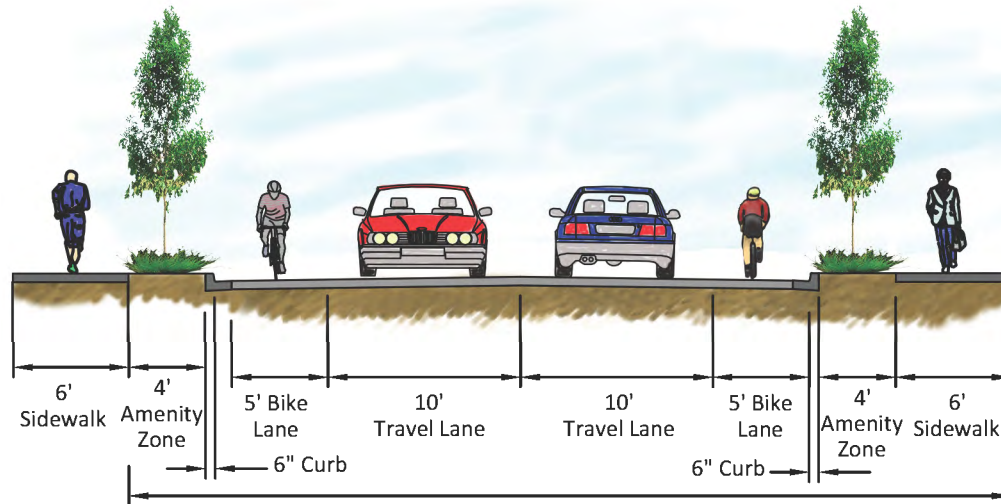

51' Developed
 Minimum 55' Right-of-way
 Existing 60' Right-of-way

NE 203rd Street
 (80th Avenue NE to City Limits-Looking East)
 Neighborhood Connection

Figure 13



APPENDIX B



**[SELECT DETAIL
DRAWINGS]**

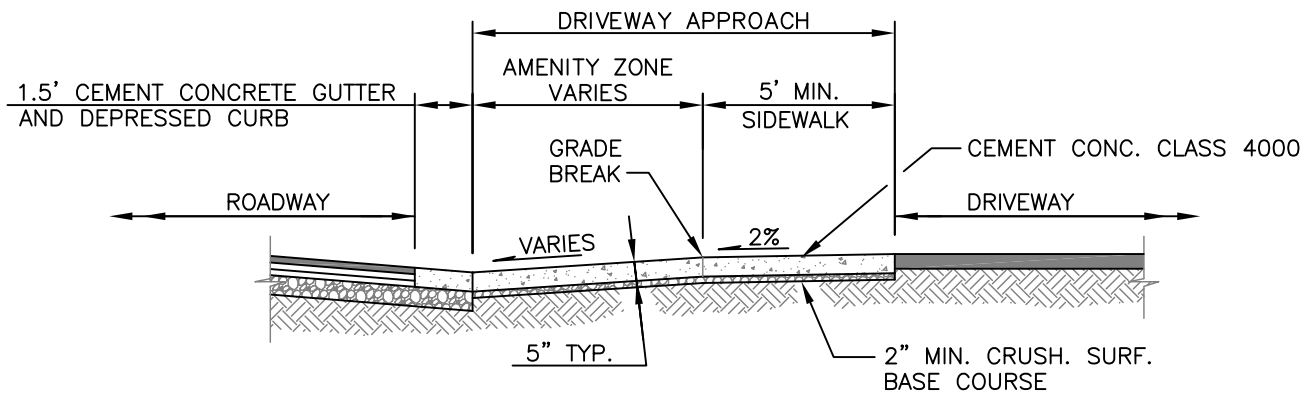
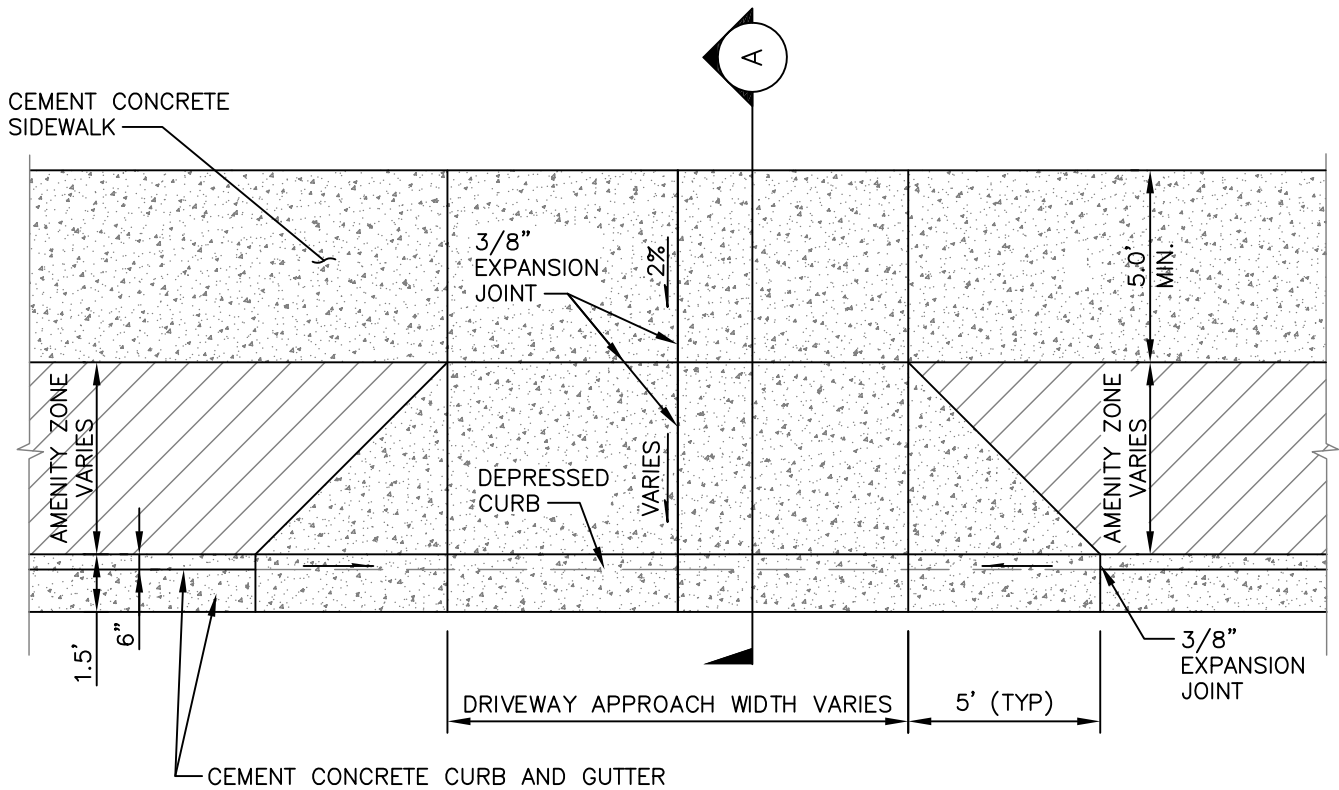

SECTION A



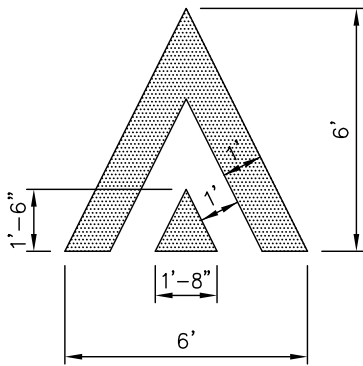

CHEVRON DETAIL

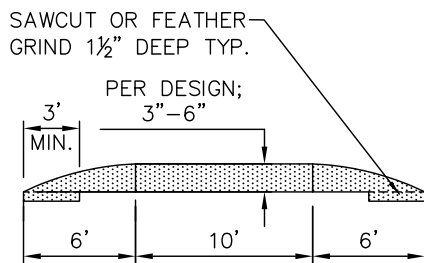

SECTION A-A

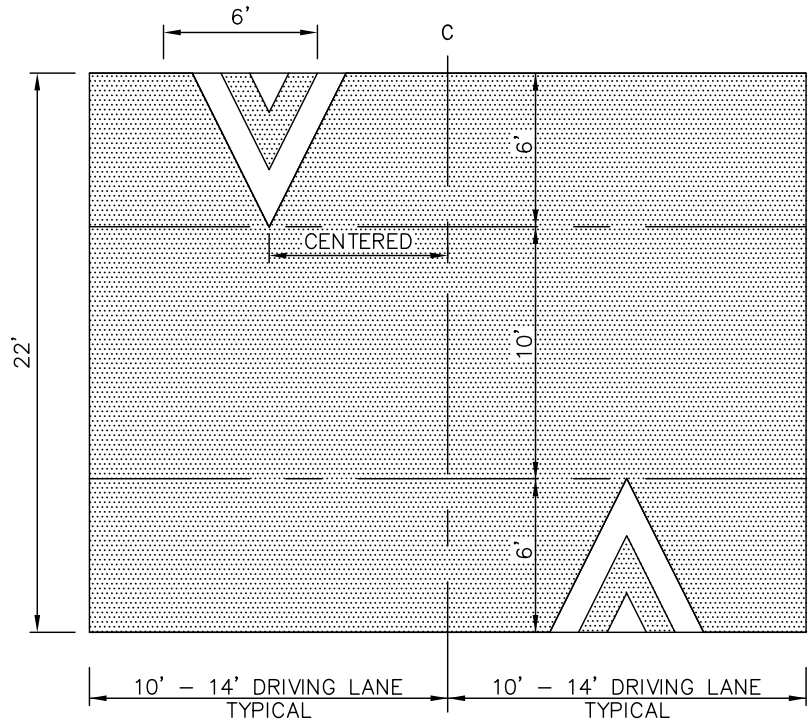

MARKING DETAIL

NOTES:

1. SAWCUT OR FEATHER GRIND TO KEY IN SPEED HUMP. SEE SECTION A-A.
2. SIGN LOCATIONS SHALL BE VERIFIED BY THE ENGINEER PRIOR TO INSTALLATION.
3. MATERIAL, COLOR, AND TEXTURE OF SPEED TABLE SHALL VARY FROM THE MATERIAL, COLOR, AND TEXTURE OF THE CROSSING VEHICLE LANES UNLESS OTHERWISE APPROVED BY CITY MANAGER.
4. SPEED HUMP CHEVRON MARKINGS ONLY REQUIRED IF ALTERNATIVE MATERIAL IS NOT USE FOR ELEVATED PORTIONS.
5. CROSSWALK STRIPING IS REQUIRED IF ALTERNATIVE MATERIAL IS NOT USED FOR ELEVATE PORTIONS
6. ADDITION PEDESTRIAN ACCOMMODATIONS, SUCH AS ADDITIONAL SIGNAGE AND/OR RECTANGULAR RAPID FLASHING BEACONS, MAY BE REQUIRE BY THE CITY
7. ADDITIONAL CATCH BASINS OR DRAINAGE CONSIDERATIONS MAY BE NEEDED TO ADDRESS SURFACE WATER PONDING AT THE SPEED TABLE LOCATION

STOP HERE FOR PEDESTRIAN SIGN, R1-5b, R1-5C, OR APPROVED EQUAL

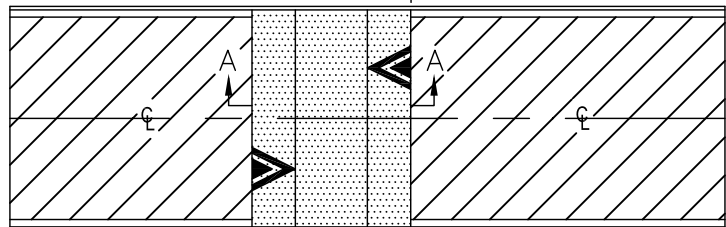

SPEED TABLE MARKING AND SIGNING



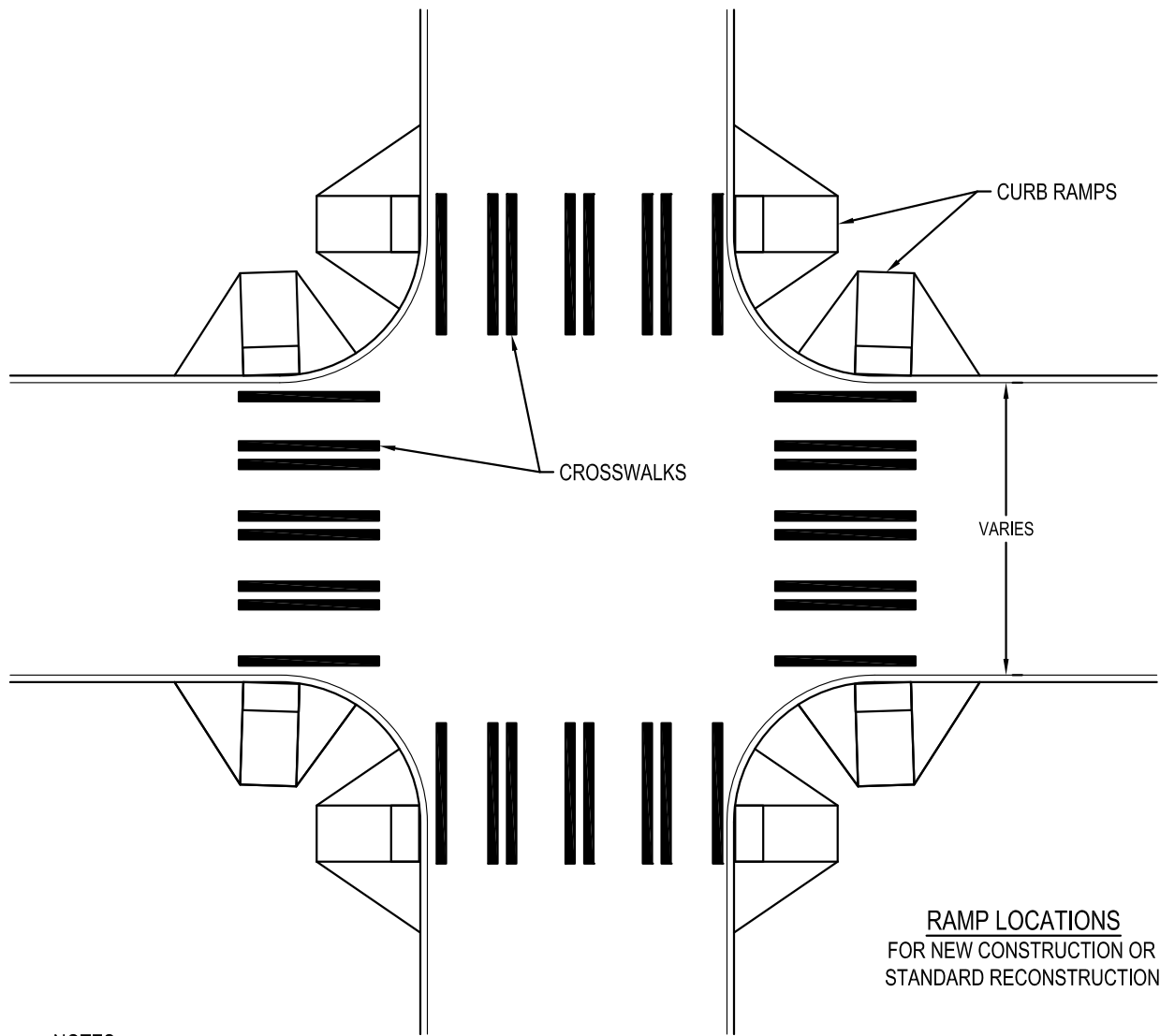

**RAMP LOCATIONS
FOR NEW CONSTRUCTION OR
STANDARD RECONSTRUCTION**

NOTES:

1. CURB RAMP CONSTRUCTION MUST COMPLY WITH CURRENT ADA STANDARDS.
2. CONSTRUCT RAMP WITH A MINIMUM 1' CLEARANCE FROM FIXED OBJECTS SUCH AS HYDRANTS, POLES, INLETS, AND OTHER UTILITIES.
3. CONSTRUCT RAMP IN ACCORDANCE WITH SECTION 8.05 AND FIGURES 8-002 & 8-003.
4. CROSSWALKS ARE NOT ALWAYS MARKED.
5. WHEN RAMPS ARE CONSTRUCTED ON ONE SIDE OF STREET, RAMPS SHALL BE CONSTRUCTED AT CORRESPONDING LOCATIONS ON OPPOSITE SIDE OF STREET.
6. CROSSWALK SHALL INTERSECT AT THE CURB OR BEYOND - NOT IN THE STREET AREA.
7. IN ORDER TO PROVIDE SAFE STREETS FOR PEDESTRIANS, DRAINAGE STRUCTURES WILL BE REQUIRED TO MANAGE SURFACE WATER AT PAINTED/MARKED CROSSWALKS WHERE AFFECTED BY RUNOFF. SEE SECTION 8.05 FOR ADDITIONAL DIRECTION.



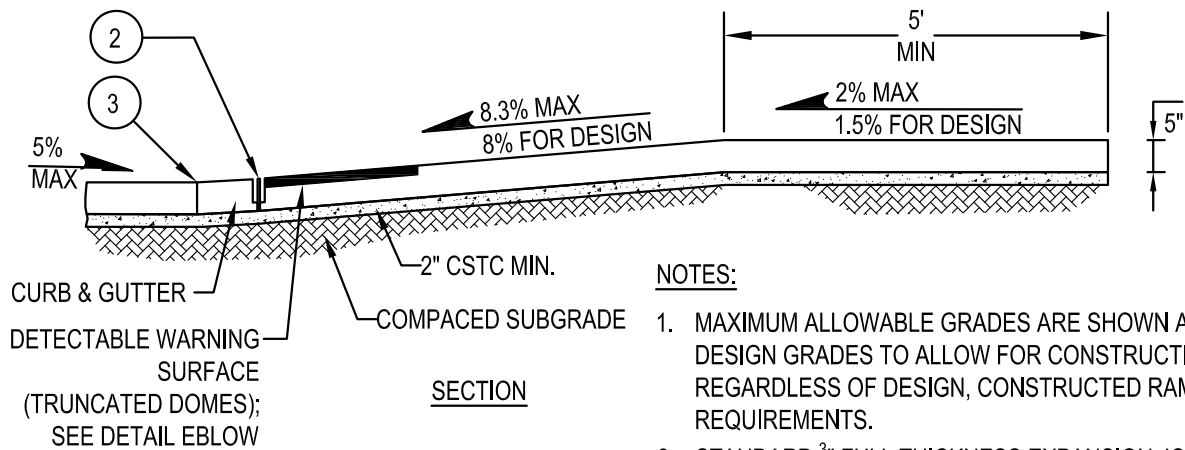
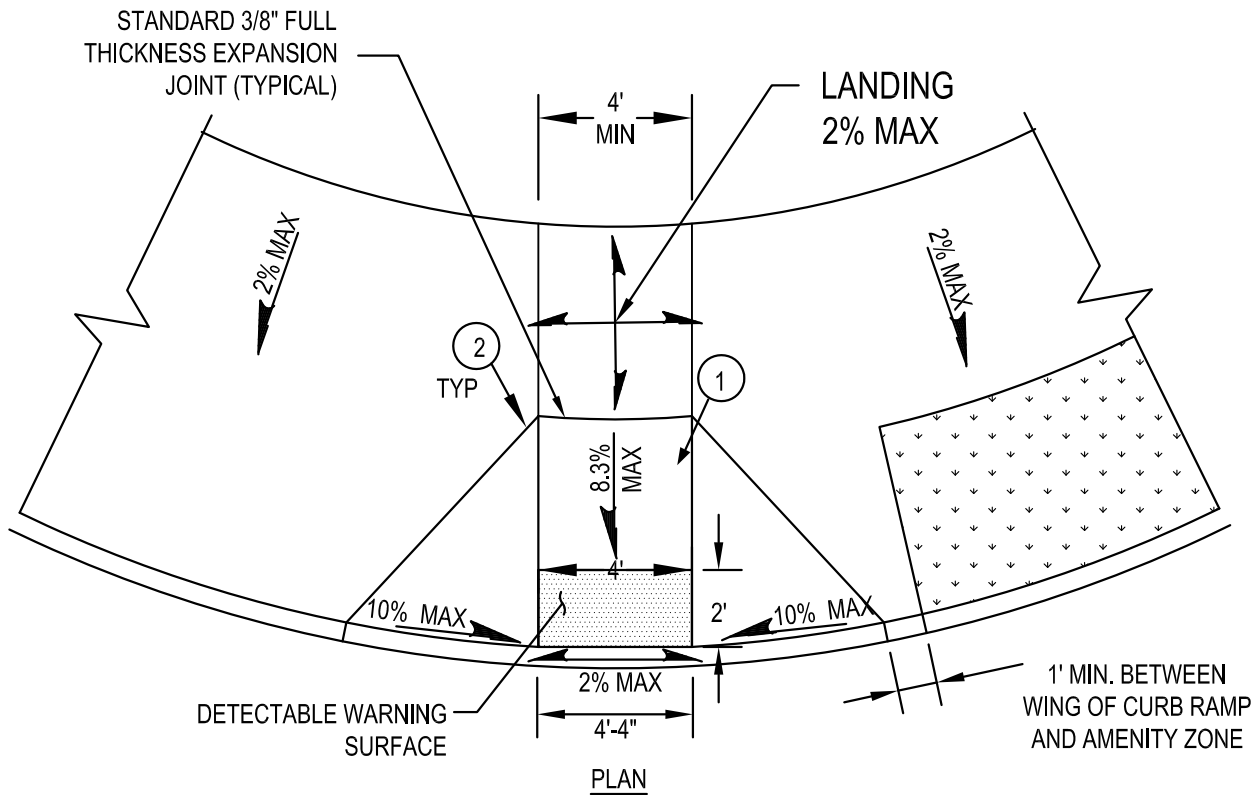

NOTES:

1. MAXIMUM ALLOWABLE GRADES ARE SHOWN AS WELL AS SUGGESTED DESIGN GRADES TO ALLOW FOR CONSTRUCTION TOLERANCES; REGARDLESS OF DESIGN, CONSTRUCTED RAMP MUST BE REQUIREMENTS.
2. STANDARD 3/8" FULL THICKNESS EXPANSION JOINT (TYPICAL). FULL DEPTH EXPANSION JOINT
3. NO LIP AT GUTTER LINE. CURB SHALL BE FLUSH AT GUTTER LINE.
4. CURB RAMPS WILL BE POURED INTEGRAL WITH SIDEWALK AND SHALL BE ISOLATED BY EXPANSION JOINT MATERIAL ON ALL SIDES, BUT NOT AT END OF RAMP ADJACENT TO THE ROADWAY.
5. CATCH BASINS & INLETS SHALL BE INSTALLED A MINIMUM OF 12" FROM THE BASE OF CURB RAMP.
6. DETECTABLE WARNING PATTERN (TRUNCATED DOMES) SHALL BE FLUSH WITH RAMP TEXTURE +/- NO GREATER THAN 1/4".
7. DETECTABLE WARNING SURFACE SHALL BE YELLOW UNLESS APPROVED BY THE CITY MANAGER
8. CONCRETE SHALL BE A MINIMUM OF 5" THICK.
9. CURB RAMPS MUST MEET CURRENT ADA REQUIREMENTS.
10. RAMP AND LANDING WIDTHS SHALL NOT INCLUDE EXPANSION JOINTS.

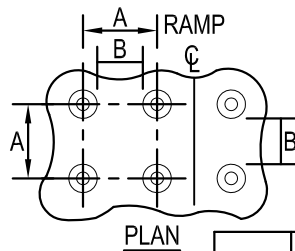

	MIN.	MAX.
A	1 5/8"	2 3/8"
B	5/8"	1 1/2"
C	7/16"	3/4"
D	7/8"	1 7/16"

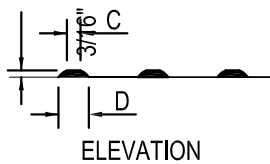

DETECTABLE WARNING PATTERN DETAIL TRUNCATED DOMES (SEE NOTES 6 & 7)



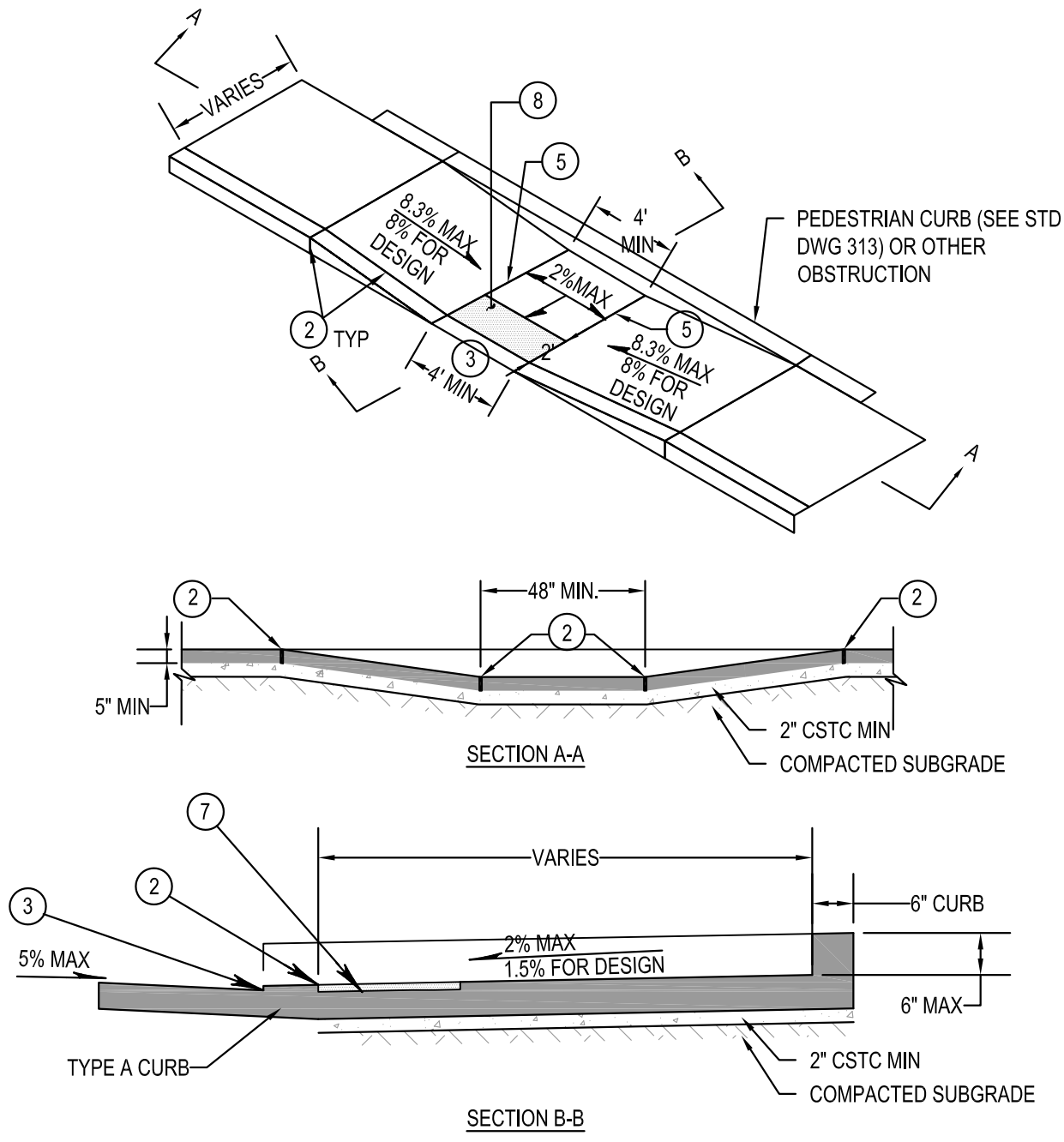

NOTES:

1. MAXIMUM ALLOWABLE GRADES ARE SHOWN AS WELL AS SUGGESTED DESIGN GRADES TO ALLOW FOR CONSTRUCTION TOLERANCES; REGARDLESS OF DESIGN, CONSTRUCTED RAMP MUST BE REQUIREMENTS.
2. $\frac{3}{8}$ " EXPANSION JOINT (TYP). FULL DEPTH EXPANSION JOINT.
3. NO LIP AT GUTTER LINE. CURB SHALL BE FLUSH AT GUTTER LINE.
4. CURB RAMPS SHALL BE ISOLATED BY EXPANSION JOINT MATERIAL ON ALL SIDES
5. $\frac{3}{4}$ " RADIUS DUMMY JOINT
6. CATCH BASINS & INLETS SHALL BE INSTALLED A MINIMUM OF 12" FROM THE BASE OF CURB RAMP LANDING.
7. SEE FIGURE 8-002 FOR DETECTABLE WARNING PATTERN (TRUNCATED DOMES)
8. DETECTABLE WARNING PATTERN (TRUNCATED DOMES) SHALL BE FLUSH WITH RAMP TEXTURE +/- NO GREATER THAN $\frac{1}{4}$ ".
9. DETECTABLE WARNING SURFACE SHALL BE YELLOW UNLESS APPROVED BY THE CITY MANAGER
10. THE CURB RAMP MUST MEET CURRENT ADA REQUIREMENTS.
11. CONCRETE SHALL BE A MINIMUM OF 5" THICK.

